

SIMPLE HULL PLANKING TECHNIQUES FOR BEGINNERS

Written, illustrated & edited by: Dirk De Bakker (kelvin12) and Greg Brooker (gregb)
With assistance from Dave Rogers (heliman41)

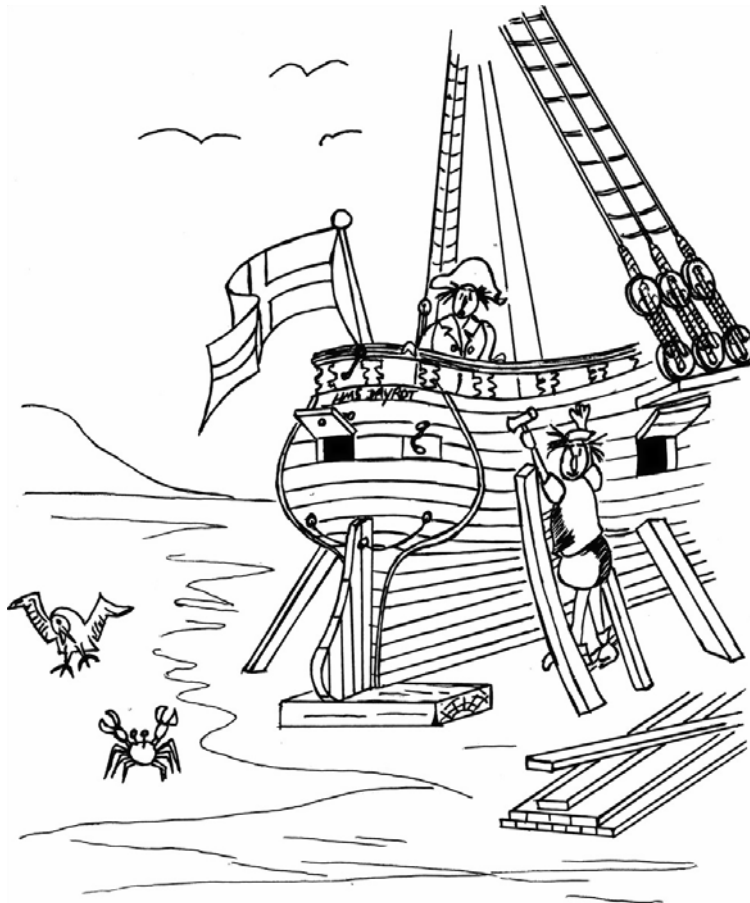

This manuscript was first published 2006 on Dry Dock Models forum with the consent of the authors. The authors' would especially like to thank **J. Luberti (Yardmaster)** for the opportunity to have this work published.

This document is copyright. Except for private study, research, criticism or reviews, as permitted under the Copyright Act, no part of this manuscript may be reproduced, stored in a retrieval system, or transmitted in any form or by any means without prior written permission. Enquiries should be made to the authors.

Table of Contents.

Introduction	page 1
1. Keels.....	page 2
2. Bearding line.....	page 3
3. Rabbet line	page 4
4. Bulkheads.....	page 5
5. Filler blocks; Bow.....	page 6
6. Filler blocks; Stern.....	page 7
7. Fairing the hull.....	page 8
8. Temporary planking battens.....	page 11
9. Garboard plank.....	page 16
10. Garboard plank; Stern.....	page 19
11. Garboard plank; Bow.....	page 20
12. Bow planking.....	page 21
13. Stern planking.....	page 22
14. Correction plank.....	page 22
15. General Planking.....	page 23
16. Cutting and fitting stealers.....	page 24
17. Rules for planking.....	page 26
18. General plank tapering.....	page 28
19. Bevelling.....	page 30
20. Fitting gun-port frames (prior to planking).....	page 31
21. Second planking.....	page 33
22. Spiling operation.....	page 35
23. Sanding the hull.....	page 37

SIMPLE HULL PLANKING TECHNIQUES **FOR BEGINNERS**

Introduction:

This project has been compiled and contributed to by a number of moderators of the Dry Dock Models forum to assist newcomers to this hobby and enable them to carry out simple planking operations. It has been put together partly in response to the numerous questions asked by new members regarding “how to do planking” and it will hopefully give them in a practical way a full and simple method to help them on their way to bigger and better things in the future.

This instruction is not to plank a ship in the traditional way used by the shipwrights of old but rather it is a simple demonstration of general methods to plank a hull to satisfactory standards that the newcomer can be proud of and display with an element of pride.

There are numerous books which deal with this operation, some of them are excellent and generally cover the full aspect of the planking operation itself to varying degrees some are a lot better than others. However it is the bits that are missing and the lack of pictorial detail that poses the biggest problems from a newcomer’s point of view.

Hopefully this project will explain some of the mystery and make the whole planking operation less stressful and painful. The plan is to show a simple step by step detailed planking procedure while explaining the reasons why it is done this way and what can occur if it is done another way. Many books touch only briefly on the stem and stern areas of a ship and as such don’t show the detailed operation required to allow a novice builder to successfully overcome what is sometimes a difficult part of the model building process.

1. Keels:

Figure 1:

This drawing shows the basic false keels of a plank on bulkhead (POB) ships. These are the most common types of false keels that come with kits. The upper one is a typical one piece keel while the lower one shows the additional components that go to make up this type of keel. The keels are basically identical to one another and the additional components shown in the bottom drawing could if needed be used on the upper keel if required.

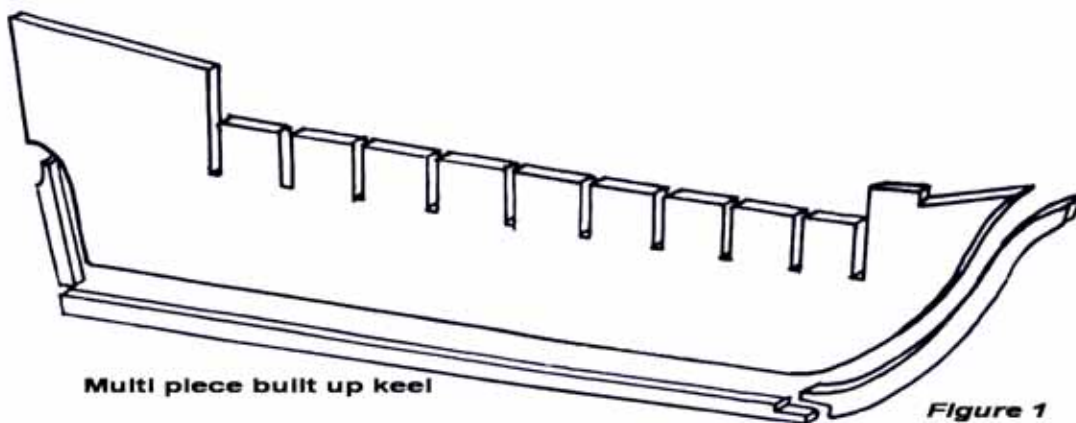
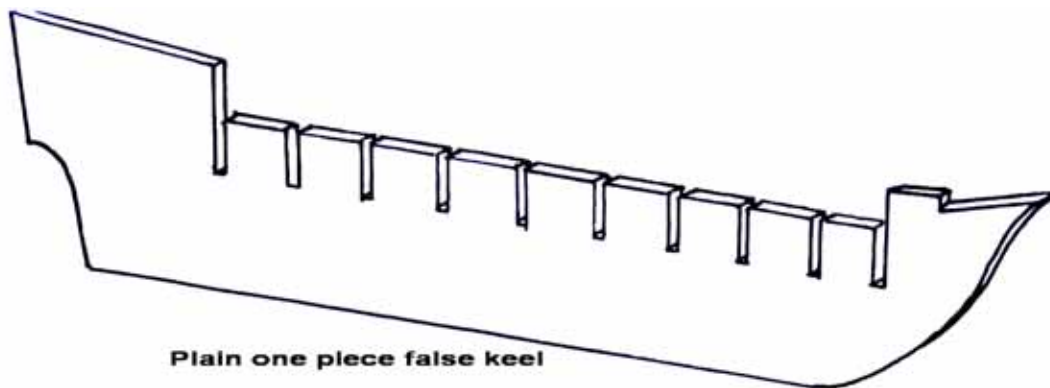

Figure 1

2. Bearding Line:

Figure 2:

This is a term used to indicate the tapered section of the false keel at either the bow or stern of the model. It is a section where extended tapering is required to allow the hull planks to lay flat against the false keel. This taper is variable from point to point and is shown on your plans and must be adhered to, to enable you to construct a faired model.

Figure 2 shows a simple method of cutting the bearding line with a sharp chisel being careful not to cut above the indicated dotted line of your plans. There are numerous other ways to carry out this operation but to make this exercise a simple matter among them are sand paper over a wooden block or the use of power tools such as a Dremel with a sanding drum are as good as any. It is really just a matter of builder preference and whatever tools he has available to him.

Sections AA, BB, CC show an approximate finished shape that will need to be obtained. Again this is approximate and the correct shape for your particular model can be obtained from the kits plans.

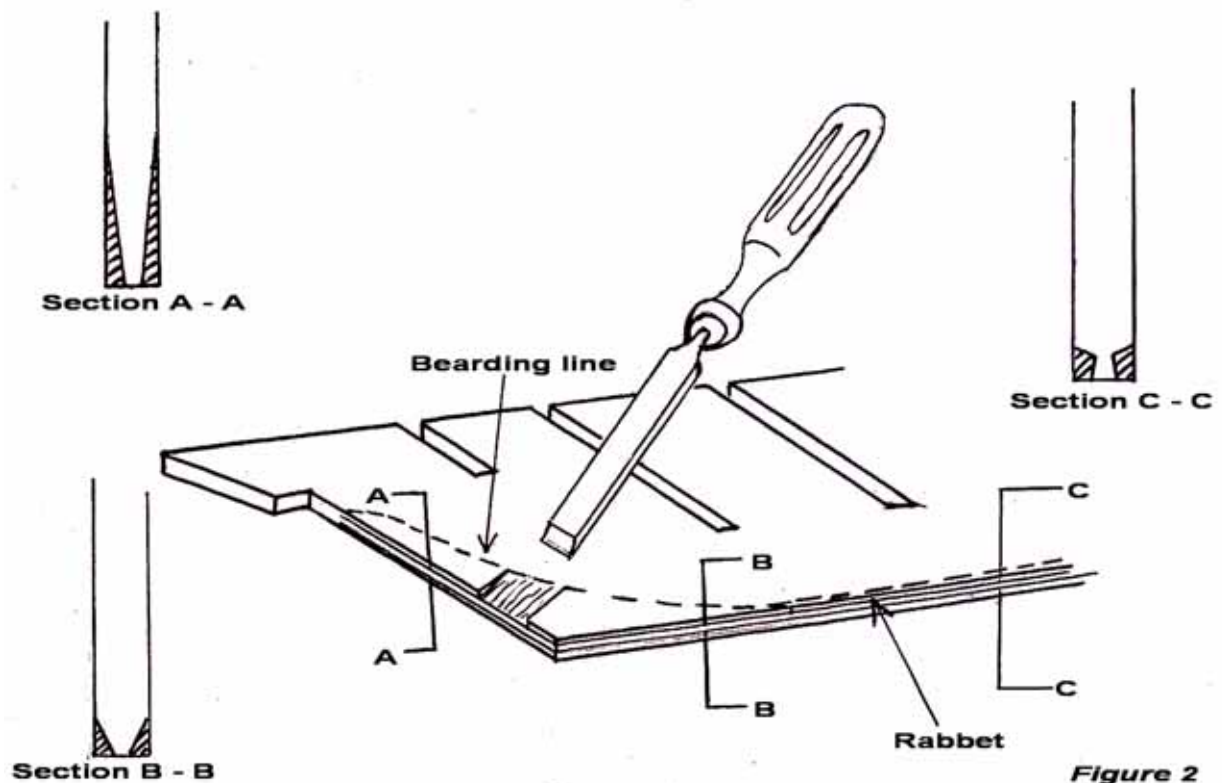

Important:

Take your time with this operation and do your best as it is important to the successful outcome and appearance of the model.

Figure 2A:

Section A shows the relationship of the bearding line to the planking at the stern of the ship. Section E shows the angle of the bearding line at the stem. In both cases if the rabbet recess is used both details need to flow into each other smoothly so as to prevent a gap or an unsightly bulge in the planking in that region. A gap or a bulge is a difficult matter to fix later when things have been glued into place so take your time and check this part of the operation carefully.

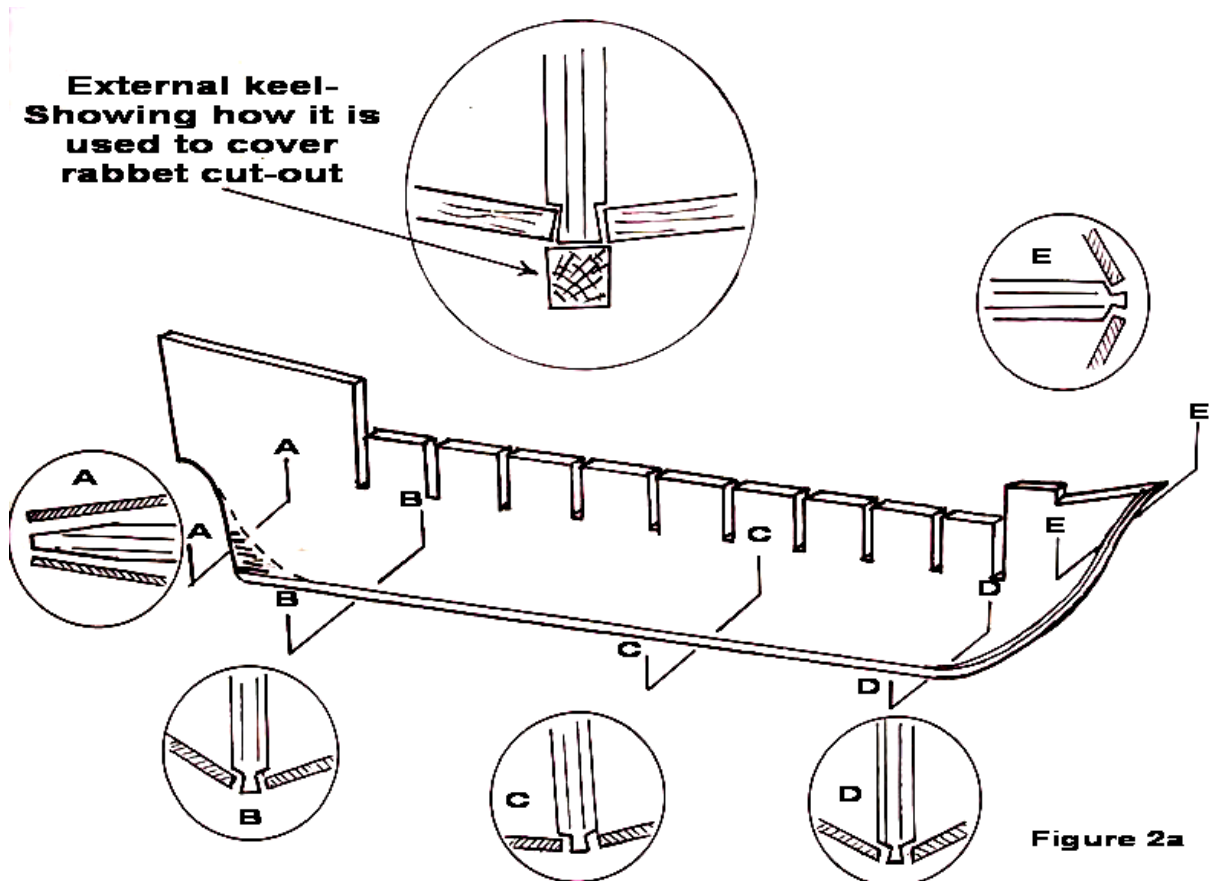
**3. Rabbet Line:**

While this rabbet recess is not strictly necessary it is how it was done on a real ship. The idea is to give the garboard plank, (first plank against the keel) a better and stronger sealing joint. The rabbet recess operation can be done away with and the garboard plank installed directly against the keel itself. There is no indication that this operation has not been carried out in the completed model. Again make sure the transition from bearding to rabbet is smooth and flowing without bumps. The rabbet recess is show in section form in *figure 2* at CC, and again in *figure 2a* at sections B, C and D.

4. Bulkheads:

Figure 3:

The bevelling of bulkheads can be carried out in the same manner and with the same tools as mentioned in the keel section. Sometimes the bevel is shown in the kits plans sometimes not. I would caution against using the plans indicated bevel though. Good advice is to dry assemble the bulkheads to the keel and check the amount of material required to be removed using the method shown in *figure 6*. The amount of bevel required can be seen by laying and pinning a temporary plank the full length of the model as shown. Do this at several points throughout the hulls length to establish this bevel. If the bevel of the kit plans looks right then bevel in the method described earlier. The correct bevel is essential to allow the planks to lie fair along the full length of the hull. Sharp or incorrectly bevelled bulkheads can cause loose, springy or lumpy planks later during the final sanding of the hull and are extremely hard to repair at a later date when the hull is ready for sanding process.

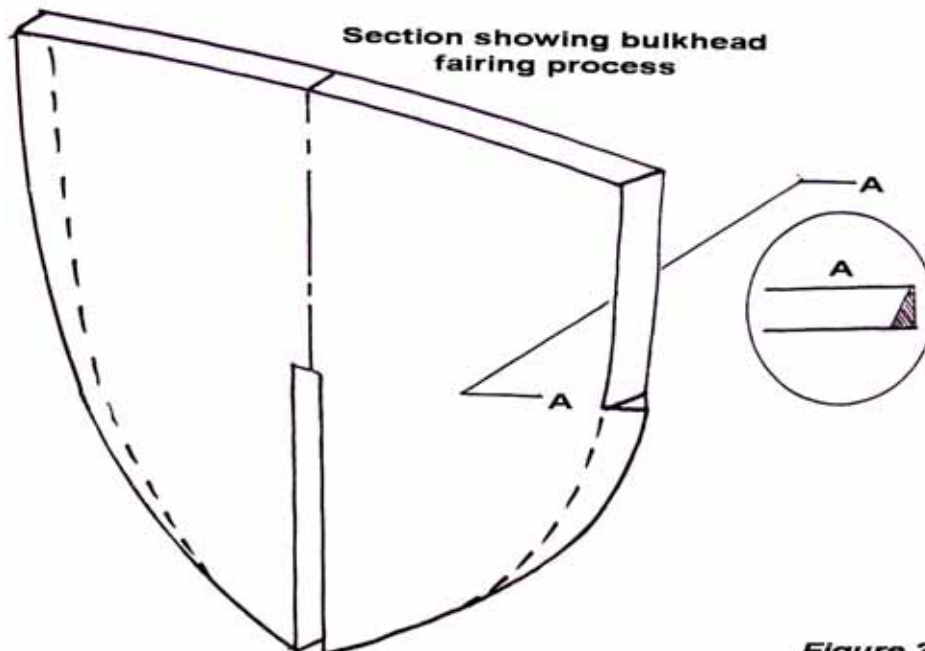

Figure 3

5. Filler Blocks; Bow:

Figure 4:

Balsa filler blocks can be used in the bow and stern sections to allow for a better controlled shape to these sections. Apart from the added advantage of superior glue surface the shape of the hull can be better formed without the use of additional bulkheads or separate formers. Some hulls are more difficult in the area of bow shapes than others. With hulls like 'Endeavour', where a real 'apple' shaped bluff bow is required filler blocks are almost invaluable to obtain the correct curvature. With another completely different form of a hull such as 'Flying Fish' or a clipper ship with smooth free flowing lines at the bow the use of filler blocks is probably not required at all, and would be a matter of choice in this case.

To build up the filler blocks a bread and butter type construction is better. Don't pay too much attention to getting the exact shape of the area at this point in time as sanding and fairing will show up any errors. It is better to have too much material rather than too little as low spots take more time to fix with the use of wood fillers. Although low spots are not a sign of a disaster they are an unnecessary problem that could be overcome earlier with some thought.

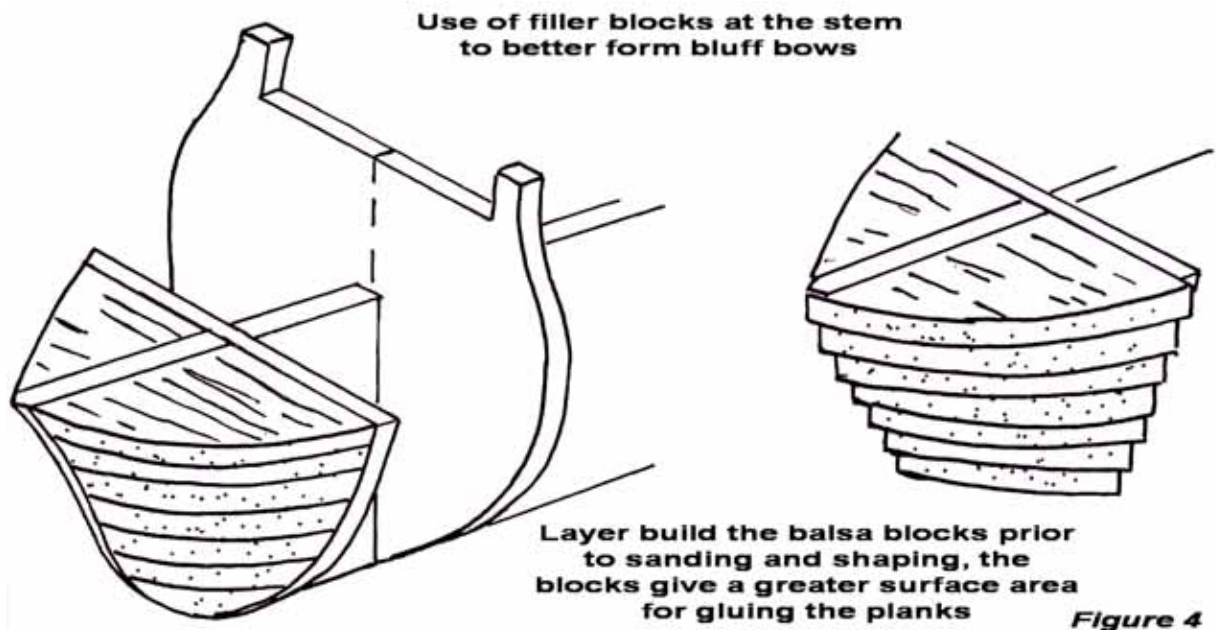

6. Filler Blocks; Stern:

Figure 5:

With the stern, filler blocks are again an advantage to obtain the correct flowing shape of the counter and transom of the ship. As in the bow the additional gluing surface area is of great benefit. Although in both instances the use of nails in these filler blocks to hold planks is doubtful due to the soft nature of balsa, if you do use nails to fix the planks be sure they go into the actual bulkheads.

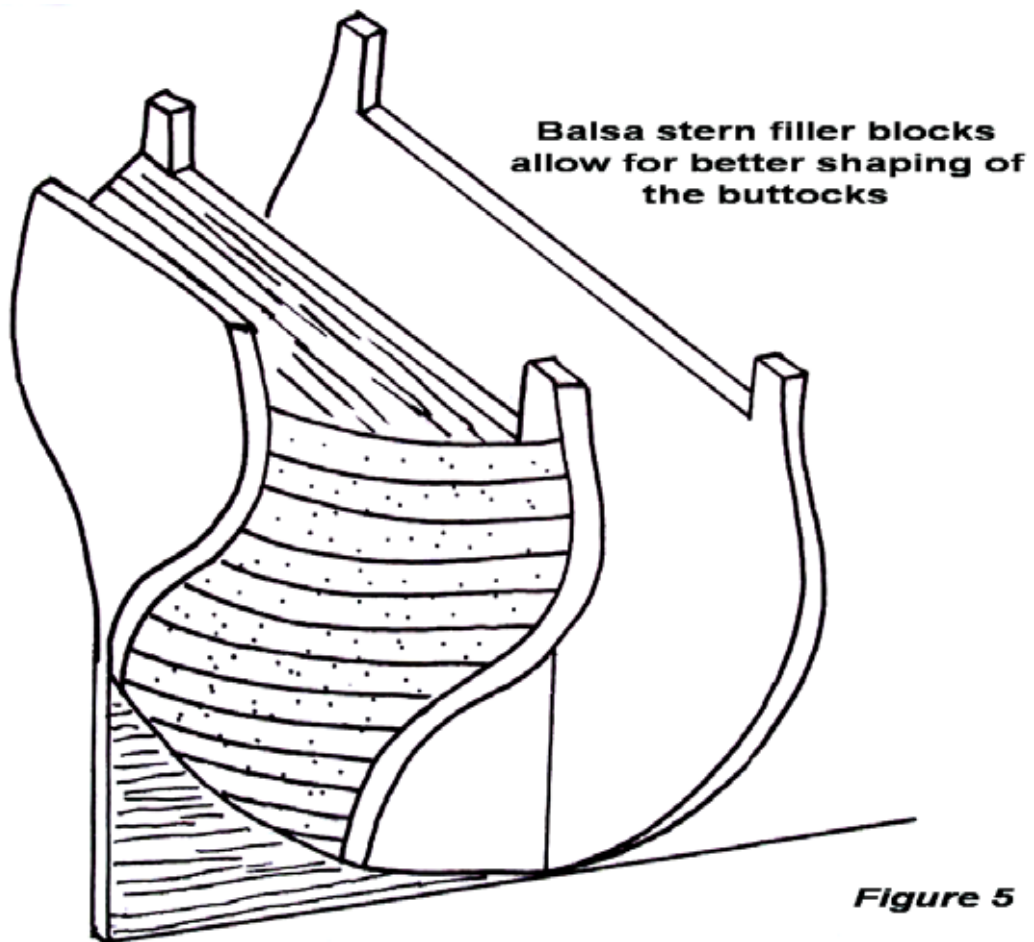

7. Fairing the Hull:

Figure 5a:

This drawing shows the smooth transition from the bulkheads to bearding line. This transition needs to be smooth, free flowing and without severe curves. If the latter occurs a depression or bump will appear in the planked hull. Again something like this is most difficult to correct at a later date. So again take your time and look at this step carefully and from all directions. Run your fingers over the transition surface or lay a temporary batten along the bulkheads to check the alignment. It is important.

**Showing the relationship
between the lower sections of
the bulkheads and the rabbet**

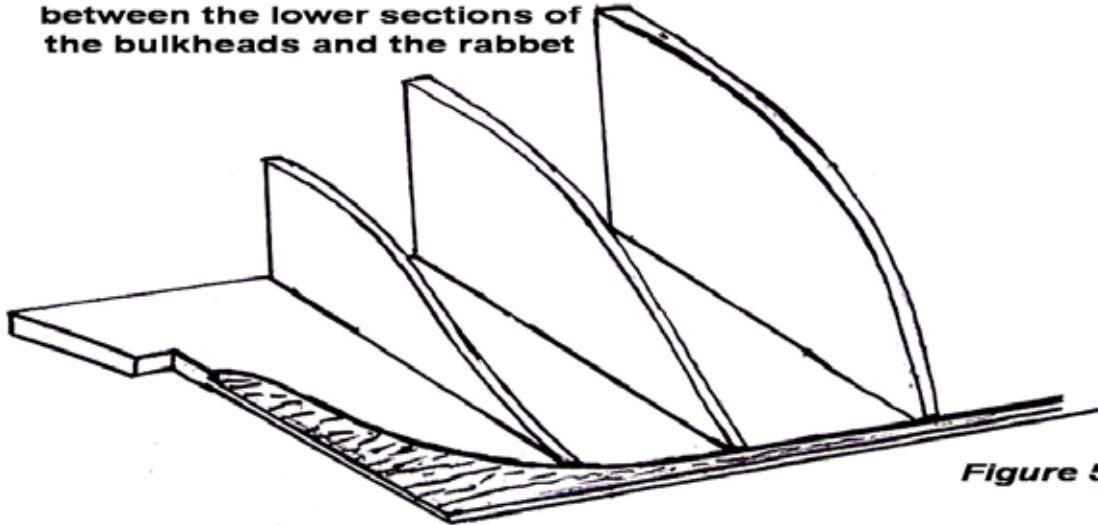

Figure 5A

Figures 6 & 7:

This is the method used to actually fair the hull and to check the lie of the hull planks along the hulls bulkheads. Take a temporary batten, something in the order of say 5mm x 1.5mm. This temporary batten must be without weak areas and knots as this will affect the natural flow of the timber being used and will certainly give you a false or incorrect reading. Pin the batten at every bulkhead station. Pre drilling may be necessary to prevent splitting the bulkheads and batten. Any type of temporary fixing (planking screws are invaluable) can be used as long as the batten is held in constant contact with the bulkhead, if allowed to bulge away a false reading will result and the hull planking will be incorrect and almost impossible to correct later. Move the batten up and down the bulkheads as many times as possible, the more accuracy you obtain in this operation the better and smoother the finished hull is going to be.

Note: Planking screws can be obtained from many hobby stores and the authors fully recommend their usage.

Take the time to look along the batten from stem to stern, look for its even smooth flow with no lumps, bumps or loss of contact with the bulkhead, this is important.

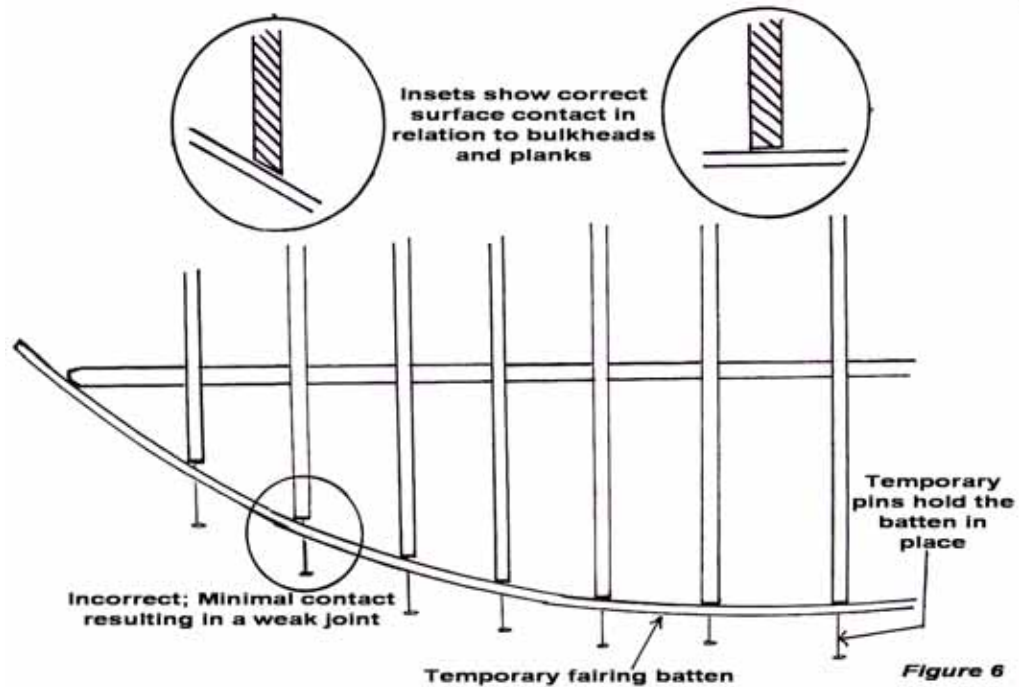

If an error is present such as a high spot move the batten up and down to determine the amount of error involved. Sand or remove the bulge to correct the problem. If there is a low spot a wooden slither or wedge can be added, just don't forget to glue the correction piece into place, no sense in allowing the piece to fall out later resulting in springy planks when trying to sand the hull down.

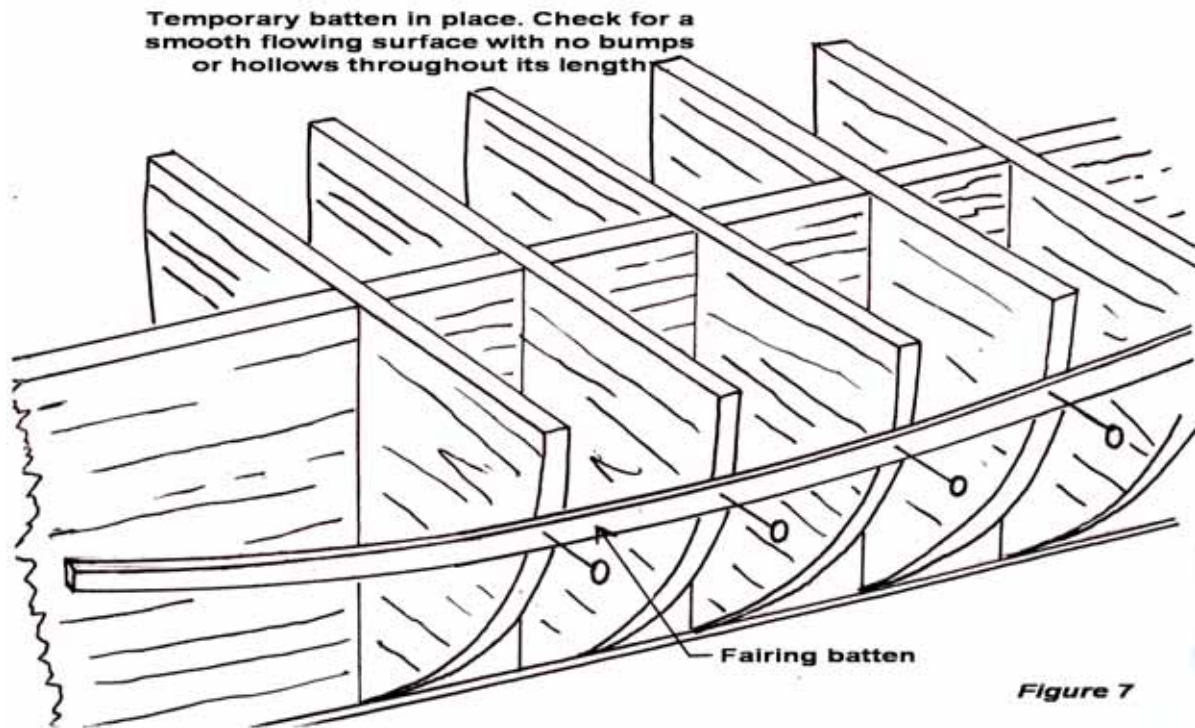

Important:

Really take your time with this “fairing” operation it is probably one of the most important procedures that will dictate the appearance of the finished model so it is well worth taking extra time to get it right. Look along the hull again and again looking at the clean flow of the hull, run your hands along the temporary batten/s. See how the batten looks at the bow and stern, is it smooth and graceful and flowing evenly. Look to see that it is and can make smooth contact with the stem piece rabbet without being unduly forced into place, make sure the transition is in the same plane and not twisted out of shape. With the stern, there are many different ways that planks join in this area. Some come to an abrupt halt on the edge of a square transom others curve up dramatically to form a very graceful flow to the counter. In all cases take a good hard long look to make sure everything is in order and flows smoothly. I can’t emphasise enough this step in the build, it is just so important.

8. Temporary Planking Battens:

Figure 8:

Temporary planking battens are also referred to as planking bands. The idea of the temporary planking battens is to break the hull into small segments to allow for the correct sizing and shaping of the planks to effectively cover this particular section of the hull. Not all segments or bands will be the same in the shape or number of planks. This is due to the irregular shape of the bulkheads and as such different plank requirements will be needed in the various segments or bands. Bands need to be about 20mm wide, this is not a hard and fast rule but at a narrower width such as this it is a lot easier to calculate and control the planks. A temporary batten needs to be in the order of 3mm X 3mm or 5mm X 1.5mm. The number required will be determined by the size of your particular hull. Bands need to be about 20mm or so wide, this will give good control of the number and shape of planks required to successfully plank your hull. As planks come in various widths depending on your particular kit judge the width of the bands by the plank sizes. Planks at 5mm wide equal a 20mm band width (4 planks X 5=20mm, 4 planks per band). Planks at 3mm wide equal a band 18mm wide (6 planks X 3 = 18mm, 6 planks per band). While this is certainly not critical it is a handy size and easy to control.

Lay the first temporary battens along the bottom of the hull adjacent to the keel. Laying the hull on a soft pillow is a good idea to prevent damage to the top sides while carrying out this step. These battens are the only ones to lay differently to the above rule because this first plank is the odd one out and is called the "Garboard" plank. The shape and cutting of this odd shaped plank will be dealt with later as a separate heading.

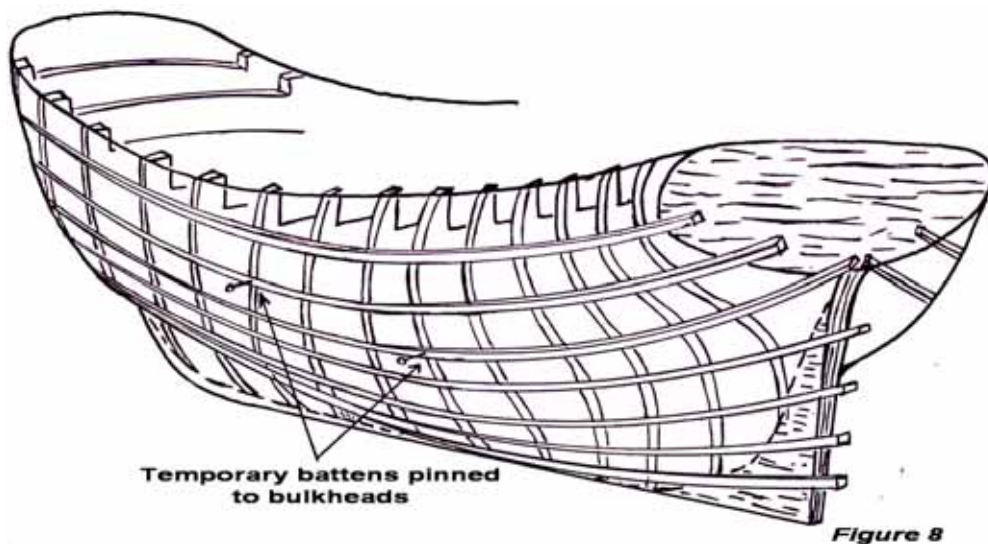

Lay this first batten about 10mm from the keel. **DO NOT FORCE** the batten into position. It must lie where it wants to go without being forced laterally across its width. If it is forced against its natural flow any other planks cut to this shape will also cause problems when it comes to their laying. Space the other battens as mentioned before at the calculated width to suit your particular planking. Again lay these battens in a natural flow try to obtain something of an equal spacing particularly at the stem and stern areas if possible. If this can't be obtained do not worry unduly as other methods can be used to break up the pattern and thereby reduce the number of planks going to the problem section. These methods will be dealt with later in a separate section.

Figure 9:

This figure shows a suggested layout of the temporary battens at the stem and stern. It can be seen that not all sections will or can be the same width at any given point and as such a greater or lesser number of planks will be used to cover these sections.

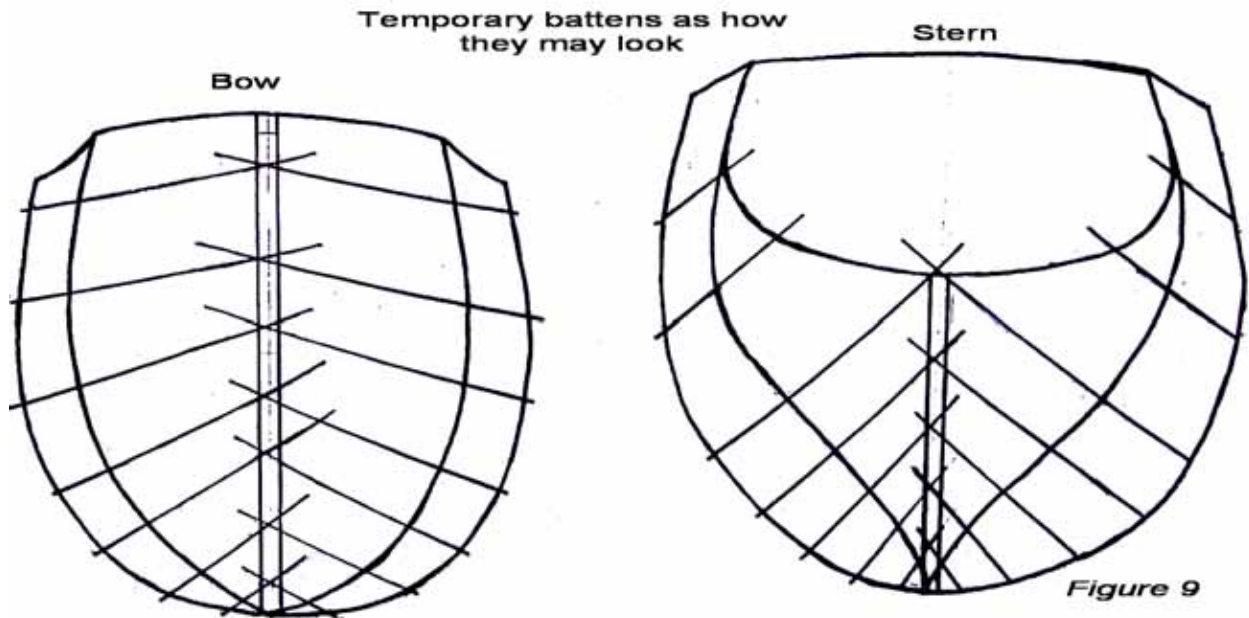
**Figures 10 & 11, 11A & 11B:**

When the temporary battens are fixed into place and you are satisfied that they are all lying naturally and gracefully along the hull and that there are no undue bends or bumps in the flow it is now time to take some measurements and go onto calculate the number and width of the planks required. Now it gets interesting as this is going to determine how your planked hull is going to look.

At this stage I might point out that we are probably going to double plank the hull as per most kits directions. However it is the intention to show you the correct way to plank a hull as if it was a single planked hull. The reasoning behind this is that if the initial 1st planking is done correctly then the 2nd planking will virtually fall into place without any real problems. If the 1st planking is wrong then the 2nd planking must be carried out from the start of this planking project to get it right. So it stands to reason if the 1st planking is right then the 2nd will usually be a breeze.

The battens should be laying the same on both sides of the hull. That is the spacing of the battens either side of the hull should be a mirror image of each other. This will ensure that both sides of the hull when completed are identical when viewed at the stem or stern.

Mark the position on the bulkheads where the battens intersect with a sharp pencil. Do this to all batten intersections on both sides of the batten and to both sides of the hull. When this is complete remove the battens completely.

With a dark marker pen or pencil make a mark exactly in the centre of the batten positions where they were laying on the bulkhead. This will give you one mark to work from on each bulkhead band rather than two where the batten used to lay. It is much easier than having to add or subtract half the width of the batten from your calculations as you advance. *Figure 10* shows you what you should have regarding the markings mentioned above.

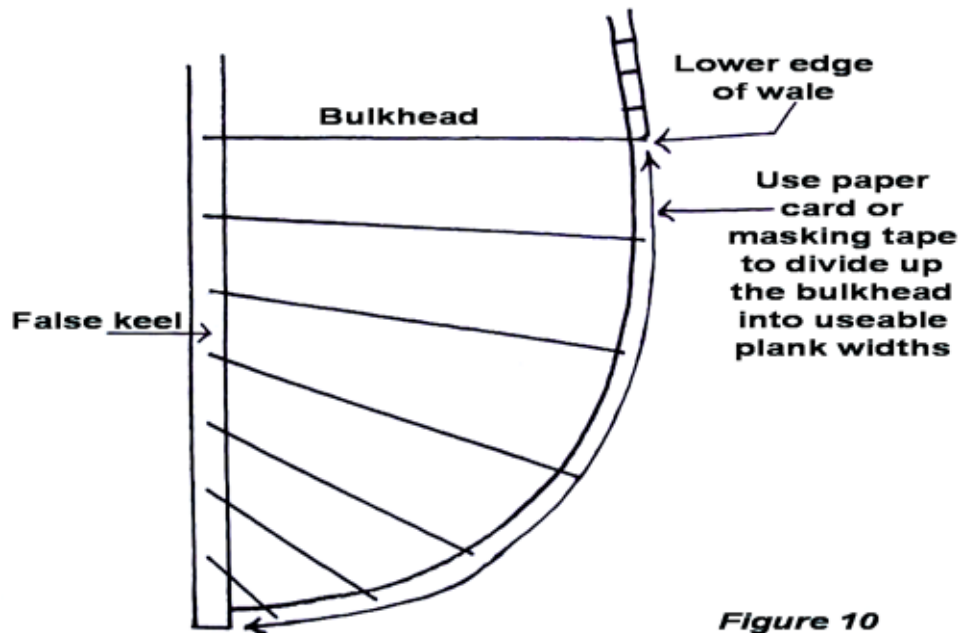

Commence at the second band as in, the first is the garboard plank band and will be dealt with later. If you wish to start with the garboard plank move to that section now and come back to this section later after the garboard has been cut and fitted.

Using masking tape or reasonably stiff paper card carefully place the card at the first marking on the bulkhead away from the keel as in *figure 11*. Lay the card around the bulkhead and on the card mark the 2nd position of the planking band. Measure this distance on the card with a ruler and transfer the measurement to the graph shown in *figure 11A*. This measurement should appear in the lower left hand box 2nd from the bottom if working from the stern, I might point out that it is easier working from the stern to the stem. Moving forward in the same band, mark on the tick-strip the width of this band at bulkhead number 7. Again measure this tick strip marking and again transfer it to the graph at the second box from the bottom of the graph at number 7 bulkhead. Carry out this operation on all bulkheads on either side. You will obviously need two separate graphs to record all the band measurements for both sides of the hull.

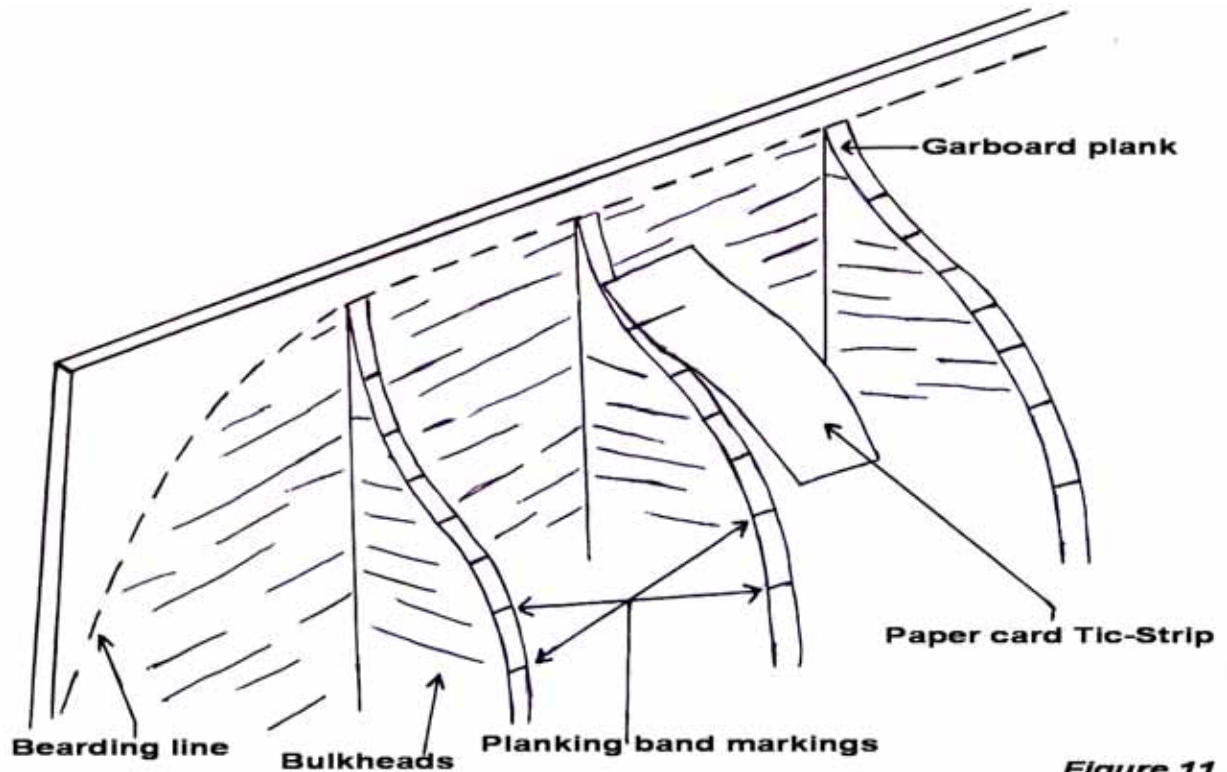

Figure 11

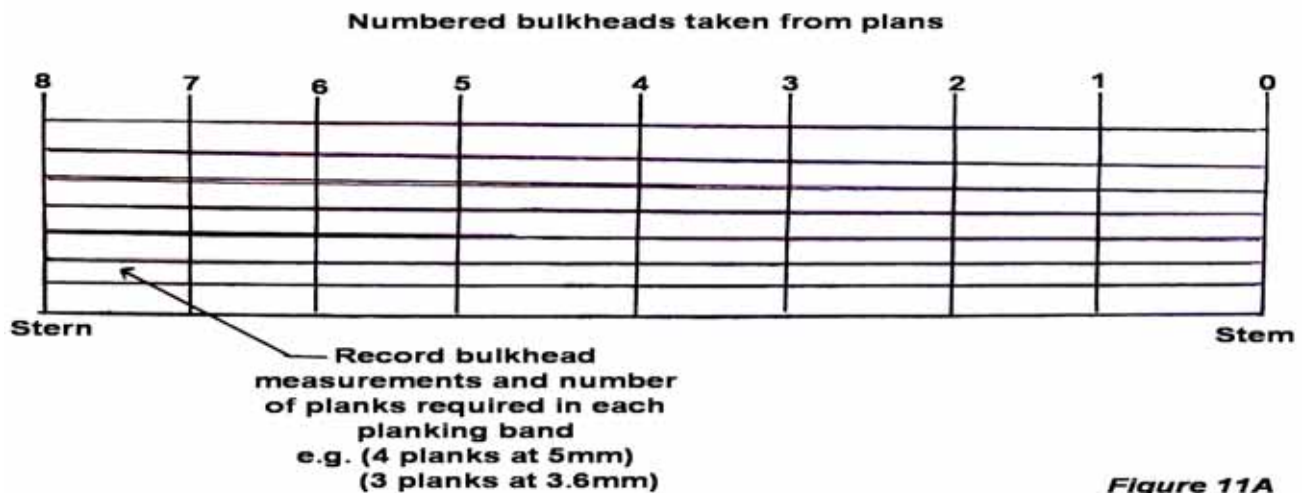

Figure 11A

From the graph divide the first measurement where you started by the width of the kits planks. Say this measurement was 15mm and the kits planks are 5mm. Therefore 3 planks will be required to fill this space exactly. However say this first measurement was 12mm. Obviously 3 X 5mm planks aren't going to fit evenly into a 12mm band.

So some tapering of the planks is going to be required of at this point. As 12mm divided by 3 = 4, this gives us a plank width of 4mm. Again referring to the graph the next band width at bulkhead 7 gives us a width of say 14mm. This also is uneven for our plank widths so again divide this measurement by 3. Still short of an exact width and still the need for some tapering. Move to the graph again to bulkhead 6, this measurement may record as 15mm. OK great, 3 X 5mm planks = 15mm exact no tapering.

On the 3 planks mark the calculated measurements from the graph. On the 1st plank start at the bottom of the plank, left hand end, mark up 4mm, at the position of bulkhead 7 mark up from the bottom 4.6mm, then at bulkhead position 6 the measurement is the full width of the plank. Take a ruler and join the dots. This is the taper required for one of these planks to fit the space required. You will note the taper only comes off the top of the plank not the bottom. This will give you a straight surface to mate up to with the lower edge of the next plank. Carry out this operation for the remaining two planks. If your tapering is correct and carefully done this band will be filled to the exact measurement at this point.

Note 1: In regard to all of the above you must always remember that the hull is upside down whilst calculating these measurements and in particular when determining which edge of the plank to taper.

Note 2: Any plank should not be tapered to any less than half of its width. If this situation arises a stealer or drop plank should be fitted and will be dealt with under its own separate heading.

Note 3: This is by no means the correct measurement for any particular ship and has been somewhat simplified to give an indication as to how the planking might actually run.

9. Garboard Plank:

Figures 12, 13, 14 & 15, A, B, C, & D:

This would be without a doubt the hardest of all planks to fit. The garboard in a real ship is heavier and wider than the other planks. Its width is different to the others because normally it is such an odd shape to lie against the keel and twist sometimes through 90 degrees to produce a straight edge for the first of the other planks to lie against. *Figure 12* shows a temporary batten secured along the bulkheads at a distance from the keel that is at the maximum width of the piece of material to be used for the garboard plank. As an example say the garboard plank is 10mm wide. Measure the distance from the temporary batten at the widest gap to the keel across the top of the bulkhead. Make sure this measurement does not exceed the width of the plank being used e.g. 10mm. At each bulkhead record the measurement from the batten to the keel, again record this measurement in the bulkhead plank graph *figure 11* in the bottom boxes.

Using a temporary batten pinned in position along the bulkheads at max width of the plank to be used as the garboard strake. Record the measurements at each bulkhead batten point to the false keel. Transfer the measurements to the garboard plank

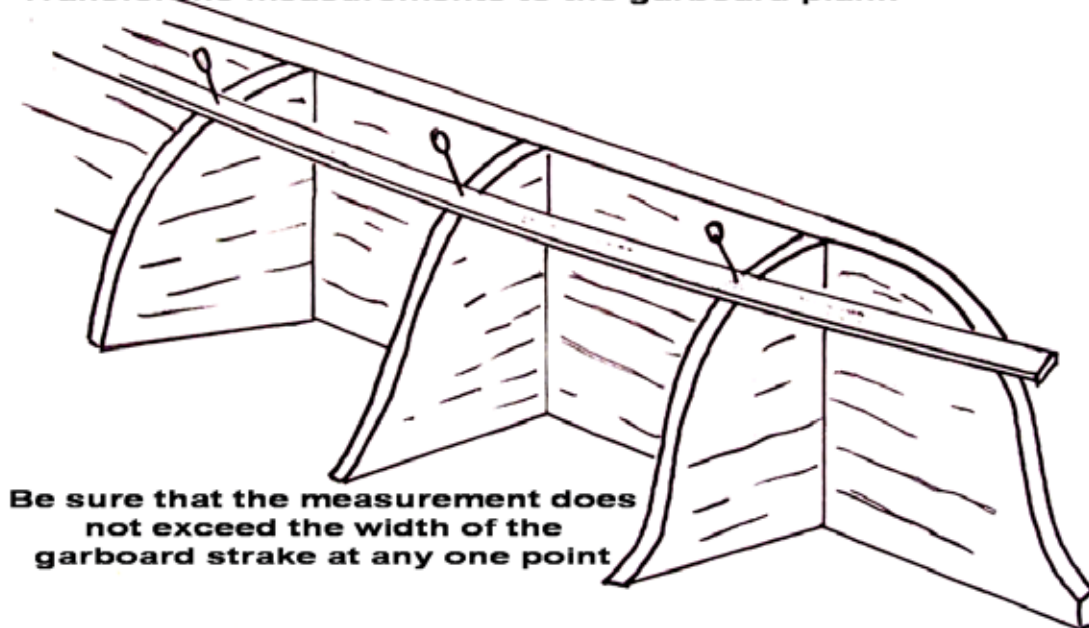

Be sure that the measurement does not exceed the width of the garboard strake at any one point

Figure 12

When the measurements have been recorded take your piece of plank and starting from the stern end this time mark downwards from the top of the plank. Make a mark as to the measurement from the graph. Likewise do the same at bulkhead 7 the measurement from the graph again from the top of the plank. Carry out this operation for the full length of the plank finishing at the stem. With a piece of paper card mark out the angle of the stem piece, cut the card to the shape and transfer this shape to the end of the plank.

I would suggest leaving a little additional length to this step to allow trimming of the plank on the job. When all marks and measurements have been checked and recorded on the plank take a plastic ruler on its edge and join the dots, using at least three dots to obtain the correct flow of the line and draw a line with a sharp pencil. Ships curves are a better option to a plastic ruler but if not available a ruler is suitable. These marks should flow gracefully without sharp humps and bumps for the entire length. Carefully cut along the line leaving a little extra material little to be sanded later to ensure a perfect fit.

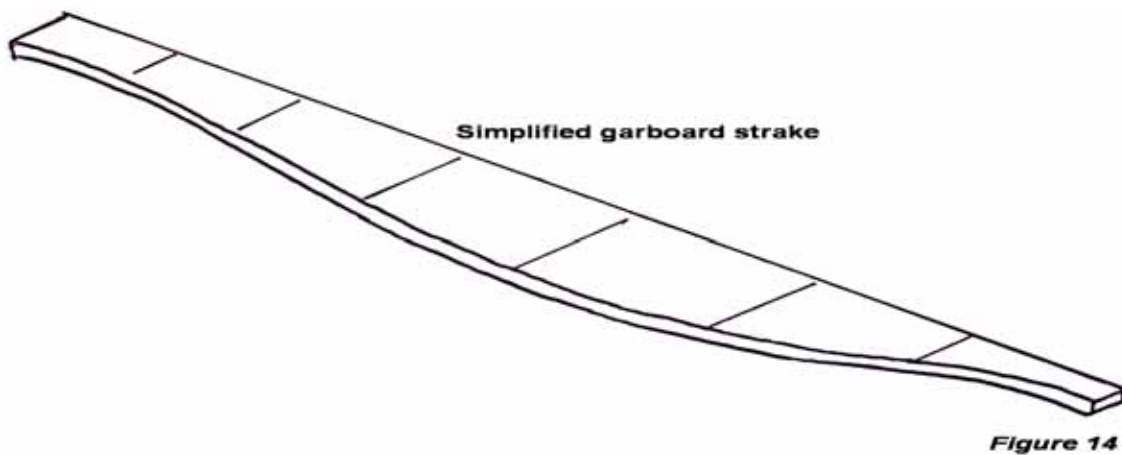
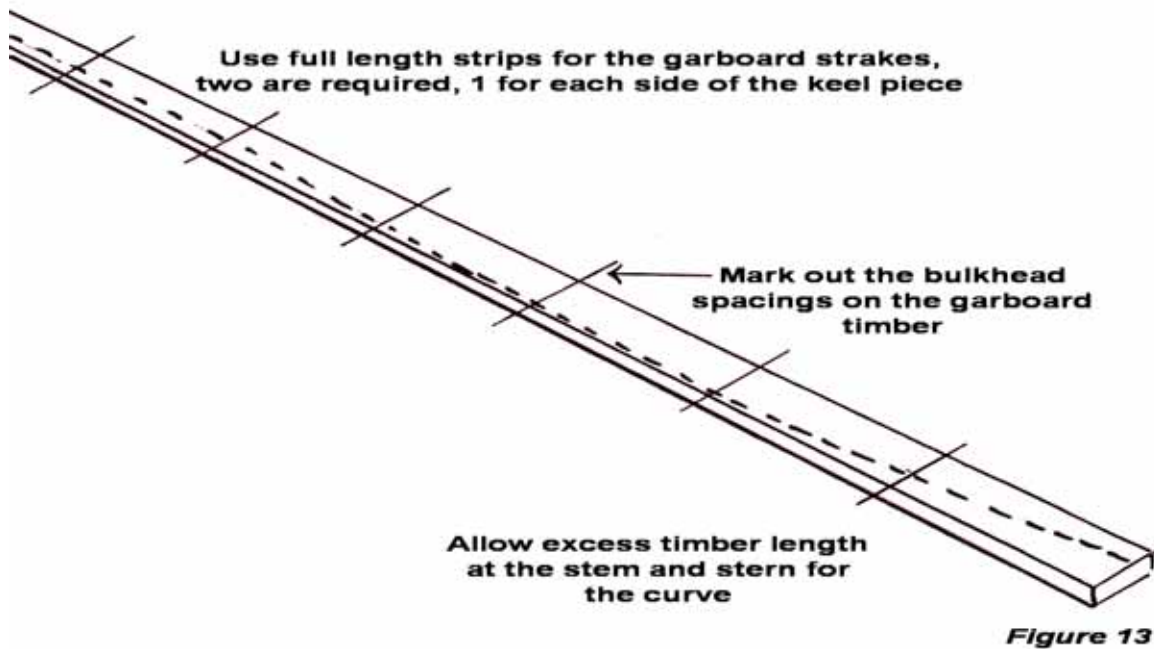

NOTE: I haven't mentioned about cutting the planks to actual scale lengths. This is a matter of choice but my advise at this stage would be to at least make the garboard plank a full length rather than cut it into separate scale lengths. This would at least get you underway with a straight edge to work from.

10. Garboard Plank – Stern:

In *figure 15* the garboard plank has been fitted. Sections AA - DD show the various angles the garboard plank goes through when it's actually fitted to the hull. This change of angle is what accounts for its odd shape, from vertical at the stern to almost horizontal at midships then back to vertical at the stem. The variation in this plank can at times be great; this is why the garboard plank should be made from wider material than the other hull planks.

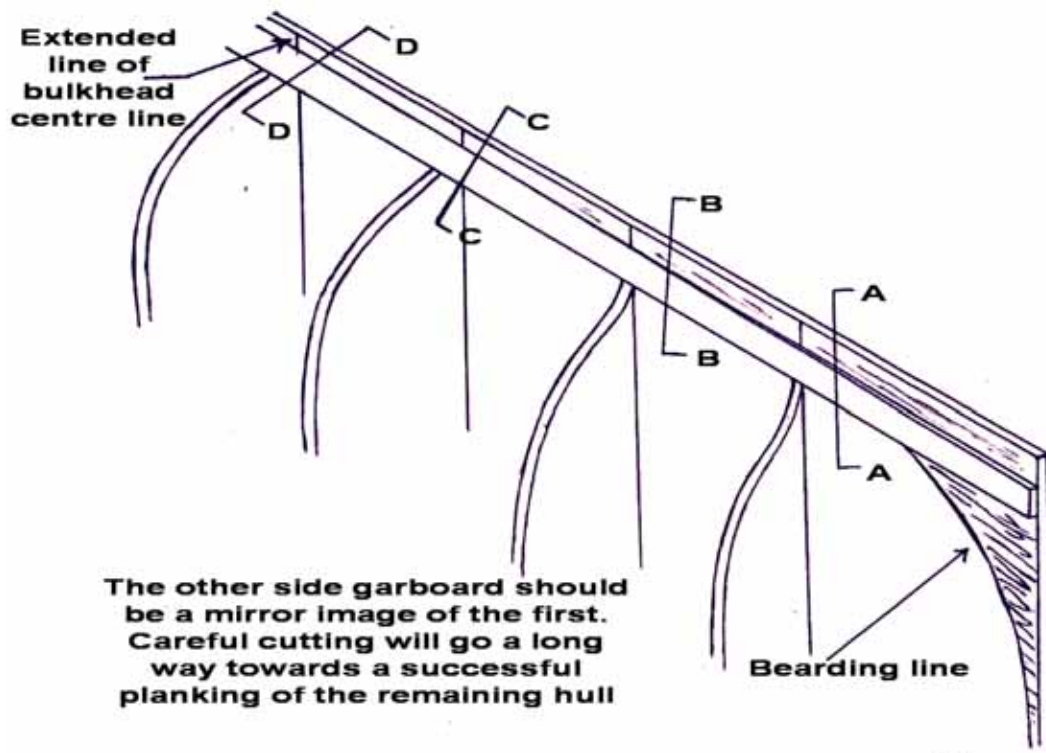

The other side garboard should be a mirror image of the first. Careful cutting will go a long way towards a successful planking of the remaining hull

Figure 15

I haven't gone into edge bevelling of the planks. As this is more than likely a double planked model and as such some small gaps at this stage would not be seen and I wouldn't worry with a second planked hull. However if your planking is working exceptionally well and you are satisfied then you could leave it as a single planked hull. It is up to you, there is short discussion later concerning edge bevelling.

11. Garboard Plank – Bow:

When fitting the garboard plank DO NOT allow it to curve up the stem piece as in *figure 15A* inset, keep it flat and straight. This is important, if allowed to curve up this will cause crowding of the following planks to the extent that numerous drop planks will need to be fitted. Drop planks are dealt with under their own separate heading later in this project.

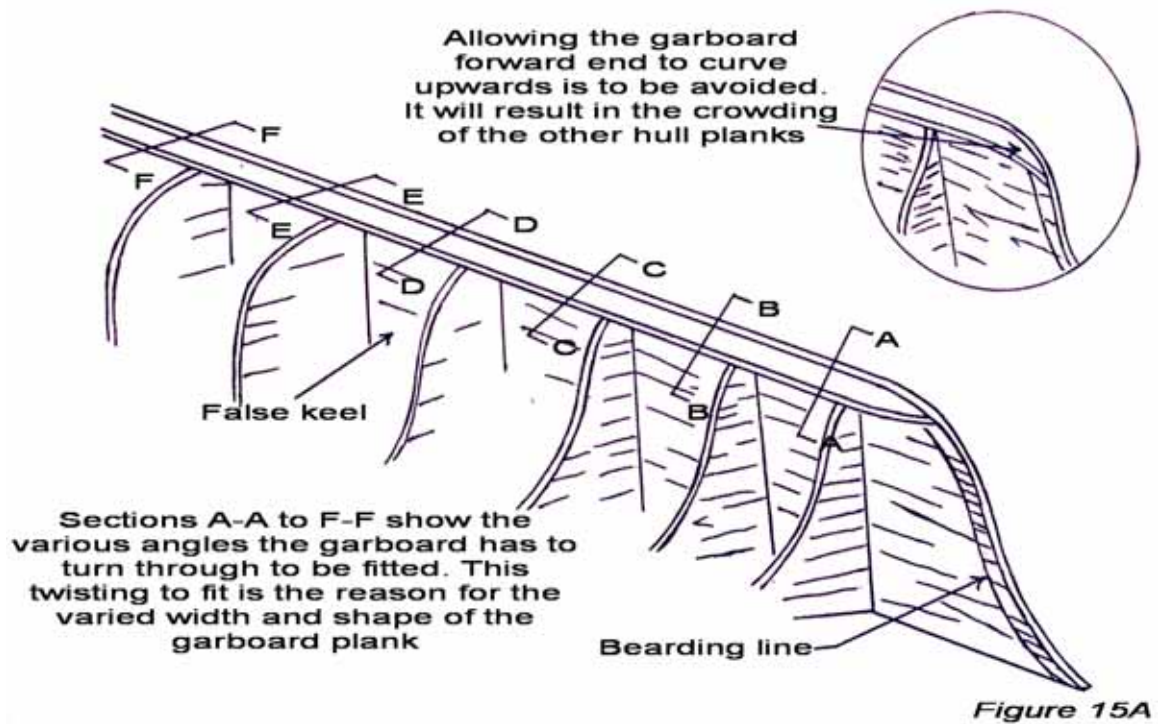

When the garboard strake is fitted calculate the remaining planks needed to fill the first band.

As this stage of the planking is carried up to the lower edge of the main wale the last plank/planks should be as near to full width for their full lengths. Some slight tapering may be required but that is all. It is appearance that we are trying to achieve and in most ships the planks immediately below the wale were full un-tapered planks. Above the wale the planks should be full length also un-tapered. However this is not always achievable.

12. Bow Planking:

During the course of planking you might in some bluff bowed ships such as 'Endeavour' or 'Bounty' for example be struck with what appears to be the need to bend a plank laterally across its width as is seen in *figure 15B*. This is real problem as the lower edge of the plank bulges out causing a clinker built look or similar to a weather boarded house where the upper plank wants to overlap the lower plank. In this situation a technique called spiling needs to be done to the plank. Spiling is described later in this project under its own heading.

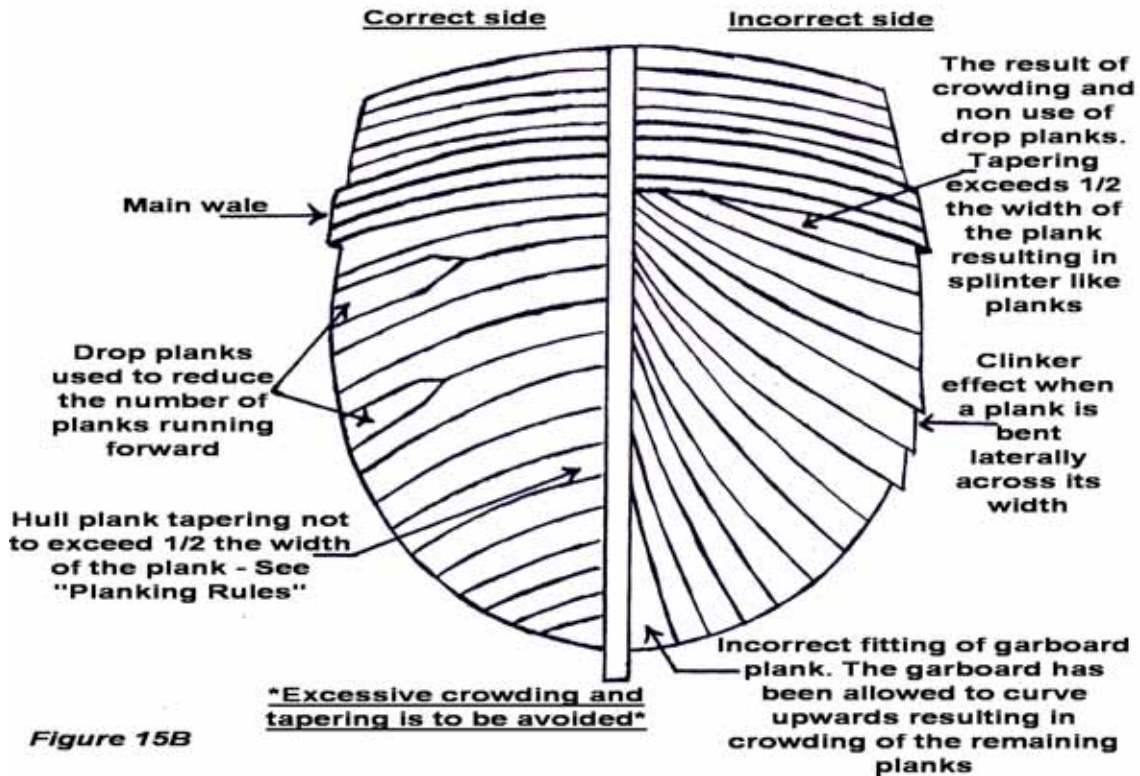

In a normal hull more than likely a drop plank would be needed rather than what is described above. Drop planks are required where bunching of the planks occurs and excess tapering would result in splinter or sharp pointed planks.

13. Stern Planking:

Figure 15C shows how stealers may or may not have to be used. There are many times when they will not be required. It all depends on the shape of the ship's buttocks. This shape is as varied as there are types of ships to be built.

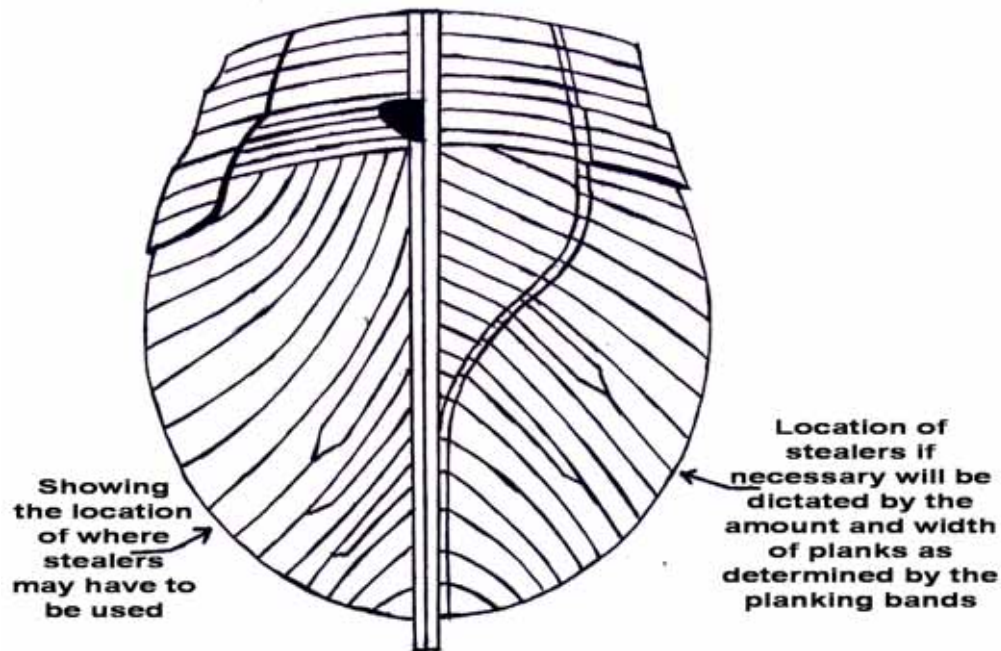

Figure 15C

14. Correction plank:

Figure 15D is a midships view where if you elected and started planking from below the main wale downward and at the same time from the keel upward you may get into a situation where despite your best laid plans there results a gap between the planks. A gap that is too wide for the plank material being used or where two very narrow planks would be required to fill the gap.

A carefully tapered and fitted correction plank can be used if needed. The correction plank should be somewhere near a standard size plank tapered at both ends and fixed over at its ends onto a bulkhead. This correction plank should not be tapered more than half the normal planks width.

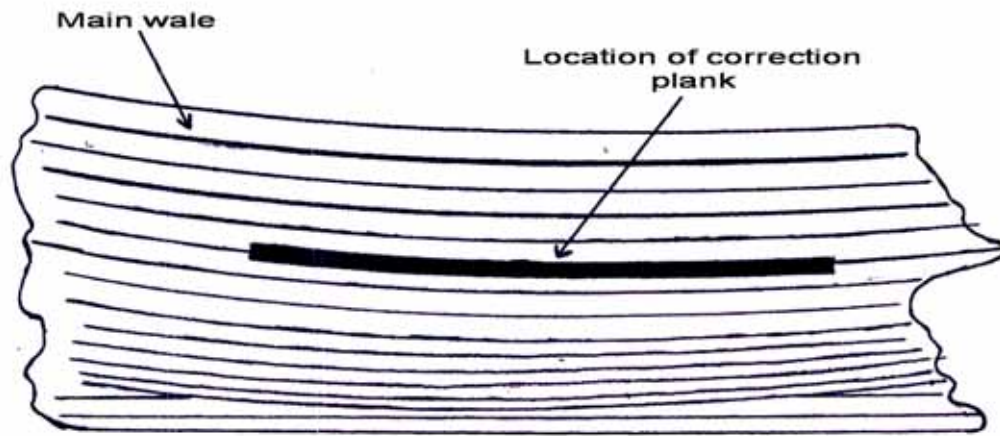

Figure 15D

15. General Planking:

Figure 16:

Moving into the full planking operation, from the bulkhead planking graph *Figure 11* determine the widths of the various planks at the given bulkheads. Cut these planks section by section fitting them into place as you move along. Don't try to cut all the required planks at once for the full ship as some creep or errors will occur as you go along. It is no good having a heap of undersized planks lying on the bench that aren't going to fit. So cut and fit section by section. At the stern if you see a droop develop immediately as in *figure 19*, think about adding a half stealer into the equation. Doing a half stealer will prevent an unnecessary full stealer having to be used so early in the process.

NOTE: Rules for half stealers and full stealers and drop planks are listed under their own heading later in this project.

If it becomes immediately necessary to add a full stealer then it will have to be done but this should only be really necessary in a hull with very full buttocks where the planks are curving up dramatically.

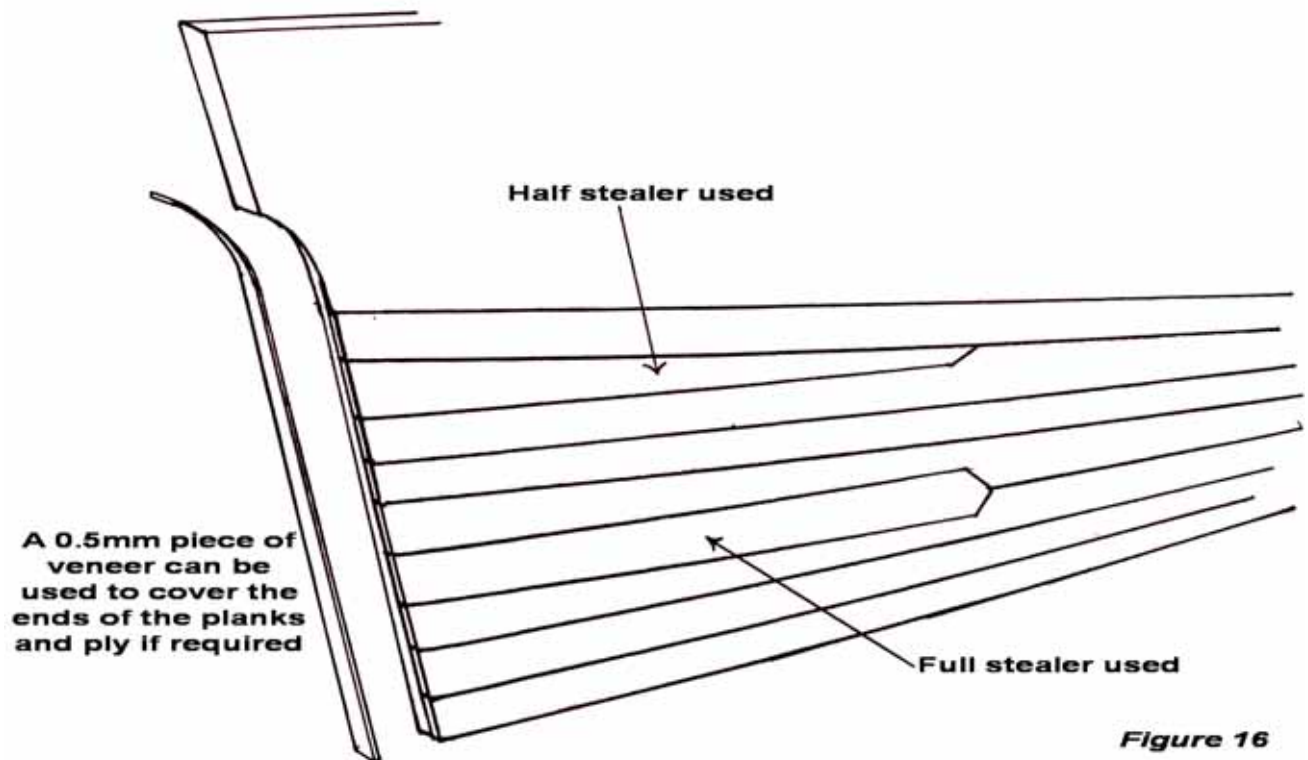

Figure 16

16. Cutting & Fitting Stealers:

Figures 17, 18, &19:

Fitting a stealer is not a problem. *Figure 17* shows where a stealer might be used to correct a widening gap developing in the planking operation. We will take a situation as in *figure 17* with a hull with full buttocks and a gap has appeared that is at or near the full width of a plank. Proceeding along you will have pinned the lower plank temporarily to see how the work was progressing before gluing this plank into position. The next plank above is laid into position but a gap appears. **DO NO FORCE A PLANK INTO POSITION** let it lay naturally. With all planks securely pinned into position on ALL bulkheads cut and shape the end of the full stealer as shown in *figure 18*. Leave this stealer longer than required.

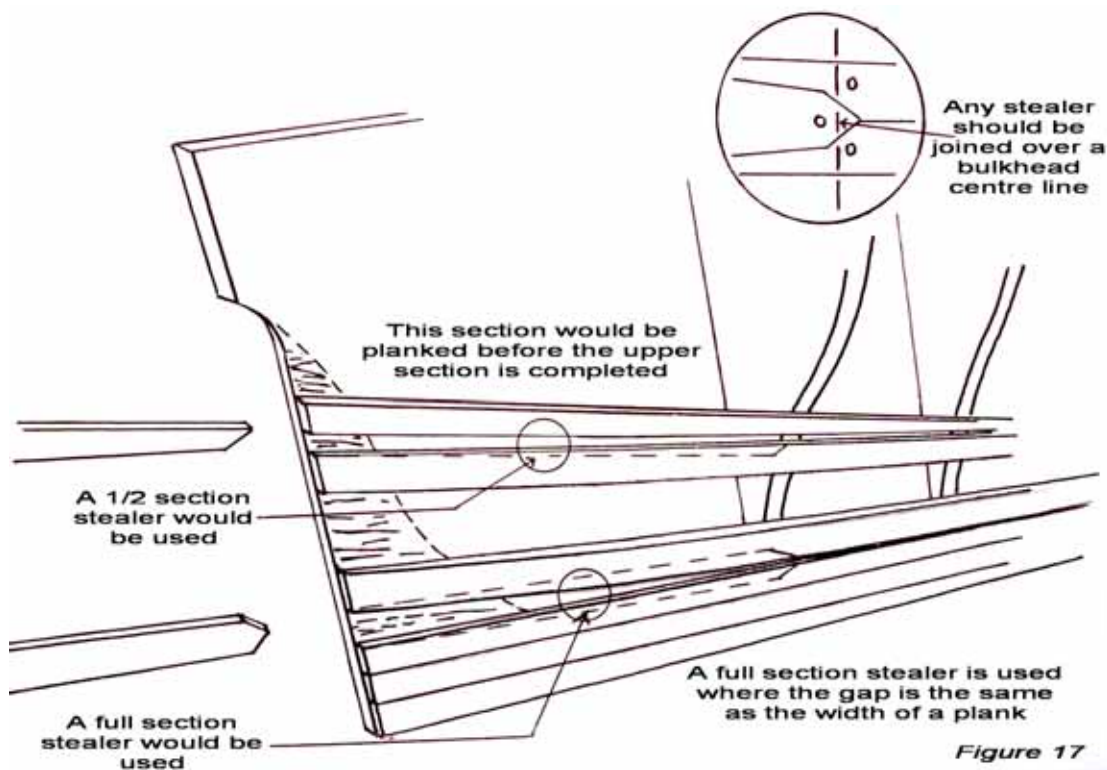
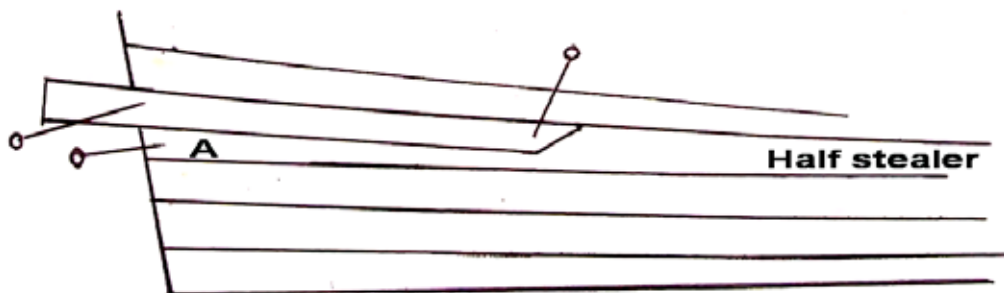
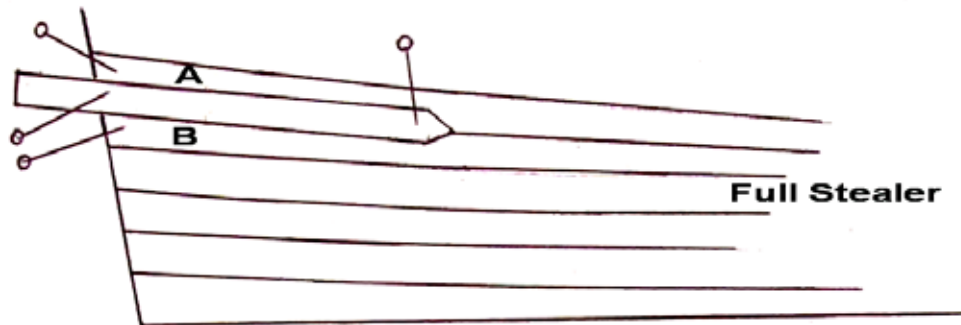

Figure 17

The end cuts of the stealer should be about 45 degrees. Place the stealer over the gap and move it forward to adequately cover the forward end of the gap, more is better than too little. With a sharp pencil trace around the stealers outline onto the planks below, remove the stealer and remove the two planks involved carefully cut away the timber not required. Sand and re-fit the cut planks to the hull ensuring they go back in the locations they came from. Carefully trim and sand the stealer if necessary, fit into place and trim to length. Mark all planks with a witness mark to ensure they fit again in exactly the same place. Remove all planks, glue and carefully fit. Job done, sit back and admire your work. Well done.

Full stealer:

Use temporary pins to hold lower plank 'B' to bulkheads. Top plank 'A' is also pinned. Shaped stealer is pinned over the top of planks 'A' & 'B'. Trace around the stealer then remove the stealer and 'A' & 'B' planks. Cut outlined shape into 'A' & 'B' planks, fit to check for accuracy and glue in place.

**Figure 18****Half stealer:**

Temporarily pin plank 'A' to be checked into position. Pin half stealer over plank 'A' and trace the outline. Remove and cut outline. Refit and check for accuracy, glue into position.

A half stealer is fitted in the same manner except only one plank, the lower plank is effected not the upper plank. It is the same procedure as for a full stealer but only half the width of a normal plank.

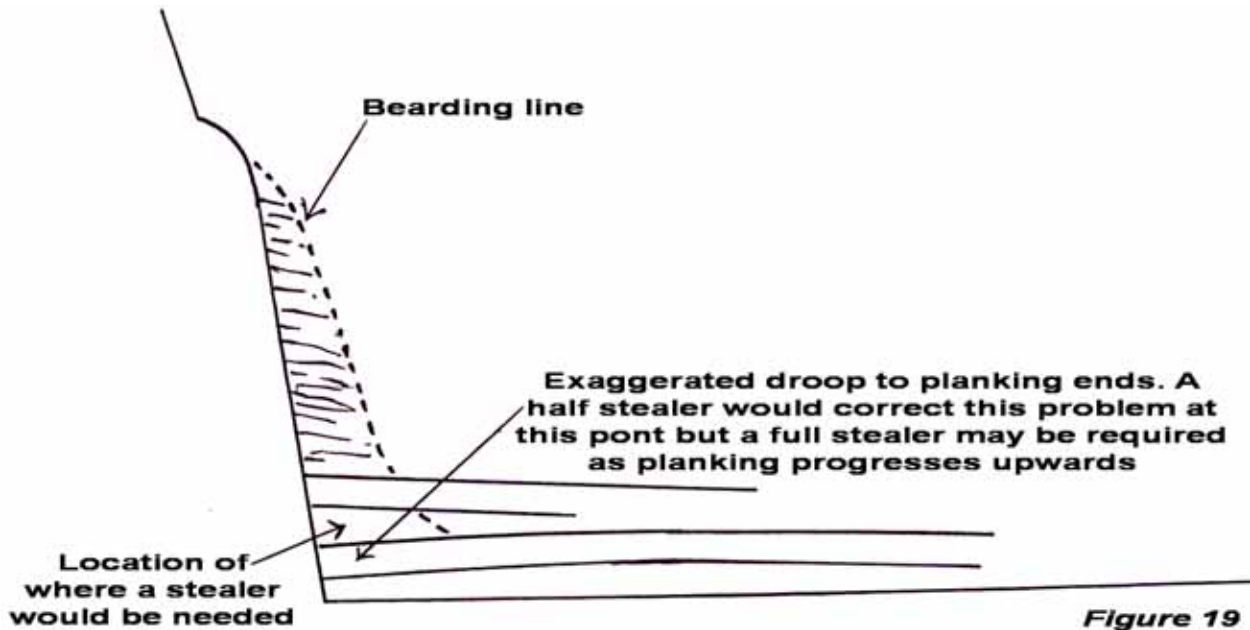

NOTE: All stealers are to be joined over a bulkhead, half and half. See *figure 17* inset.

17. Rules for Planking:

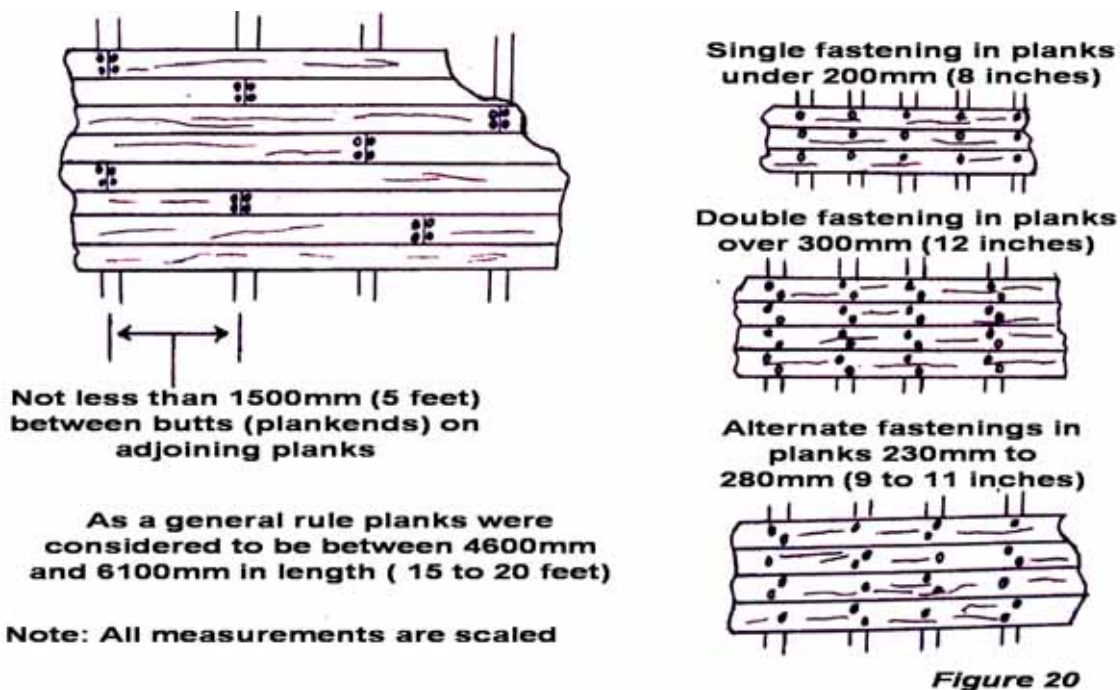

Securing the planks

Securing the planks, there are time honoured rules for securing the planks to the hull of. *Figure 20* deals with and shows these rules as they applied, together with the methods used for fixing the planks to the frames (bulkheads) using tree nails as a method of securing the planks.

Stealers & Drop Planks:

Half Stealer:

A half stealer is used generally in the stern section and probably fairly close to the keel. If a droop develops in the first couple of planks above the keel as in *figure 19* it is time for a stealer. As with all planking don't be too eager to glue the planks into position because in the case of a stealer the last plank fitted is the one that has to be cut to let the stealer into it. So of course the plank that has to be cut has only been pinned, hasn't it? Make a decision as to the length of the stealer that is going to be needed. Allow a small addition to the length for snug fit. Shape the end of the plank at an angle of approximately 45 degrees as shown in *figure 21*. The forward end of the half stealer will need to be tapered but no more than half its own width is allowed for this process. See A-A of the half stealer diagram. Any more and the plank will be like a splinter and not shipwright. To the stern end of the plank again the taper should be no less half the width of the plank, however B in the diagram shows a more realistic taper that would be required somewhere in the vicinity of $\frac{3}{4}$ of the planks width. Of course the upper half of the diagram is the section that is actually the half stealer. To carry out this operation shape the half stealer as described above after determining the width of the stern section of the stealer. Pin this stealer over the previous pinned plank and mark out the outline of the shaped stealer. Remove both stealer and under plank, cut under plank carefully. Trial fit both and sand to obtain an accurate fit, if all fits well glue into place.

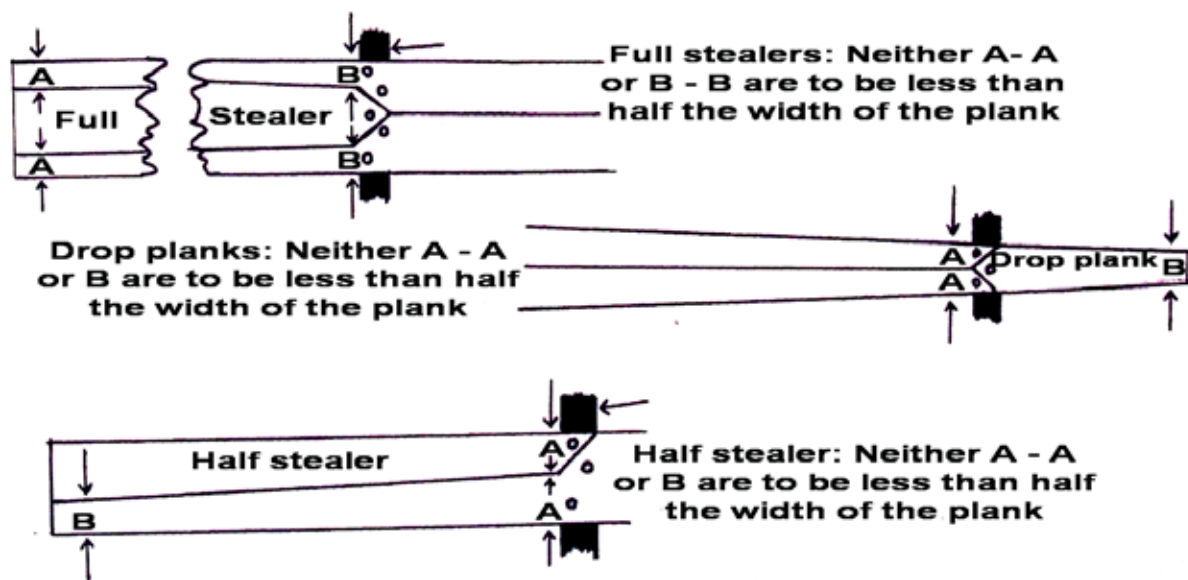

Note: All stealers, drop planks and correction planks are to be joined over a bulkhead centre

Figure 21

Full Stealer:

A full stealer is made up in the same manner as a half stealer except its end section consists of two 45 degree cuts. Again this end of the stealer BB should be no less than half the width of the plank. However the stern end of this stealer is to be the full width or close to it. Again the two under planks affected should have been pinned into place to determine the length of the stealer required, cut and shape the stealer as in the diagram. Place and pin it over the top of the under planks. Mark around the outline and remove. Cut the under planks to suit and trial fit. Sand if necessary and glue into position if all is well.

Drop Planks:

Drop planks are used to reduce the number of tapered planks going to the bow section. In effect a drop plank reduces two plank widths into one plank width. These are used where crowding of the planks is starting to occur and if not used the tapered ends of the planks would be mere splinters. Similar rules apply as in stealers. Again the forward end of the drop plank is not to be tapered more than half the width of the plank. In the two planks coming forward at section A-A they are not to be tapered any more than half the width of the plank. As with the other stealers and as a drop plank is technically a stealer, place the shaped drop plank over the ends of the planks affected to ensure a flowing fit to sections A-A. Pin into place and mark the forward end where it fits into the stern rabbet. Allow a little extra at the point for a snug fit. Sand as required and glue into position.

Note: All stealer and drop planks must be secured at the joints with the under planks over a bulkhead, half and half as in *Figure 17* inset. This will ensure a solid surface to the completed hull and when sanding operations are carried out. Failure to do so can result in a springy joint that is extremely difficult to fix after the planking is finished.

18. General Plank Tapering

Figure 22:

The top tapered edge mates with the un-tapered bottom edge of the next proceeding plank. This makes a smoother flow of the planks at the ends of the ship and prevents the planks twisting and dropping away at the ends.

With bow planks start the taper just forward of midships and again only taper to half the width of the plank.

Stern tapering is a little different. Lay the plank over the under plank and note where the planks intersect, mark and taper from this point. The difference here at the stern is because of the full buttock shapes of the stern bulkheads. The situation I have just described does not occur in all ships, some require tapers similar to the forward sections. It is a matter of studying your particular ship and test fitting the planks to see where they want to lay. Remember do not force a plank laterally. This will almost certainly result in the planks forming a clinker like position which is hard to overcome. If you see this situation developing then spiling of the offending plank is required.

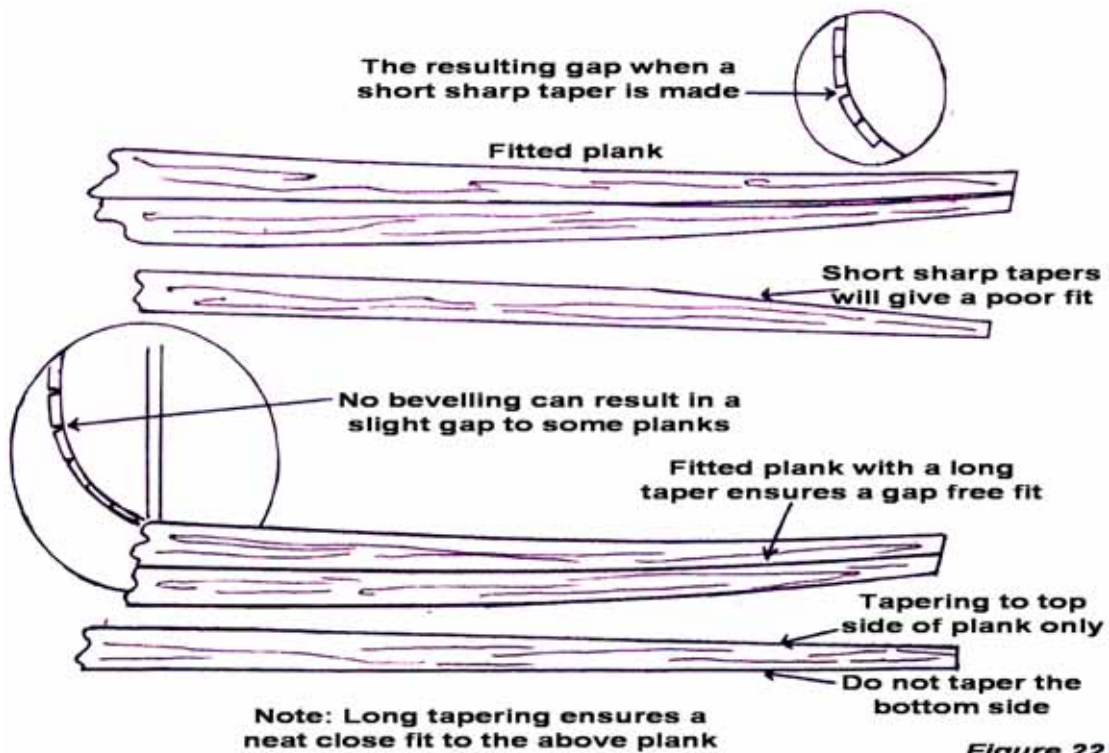
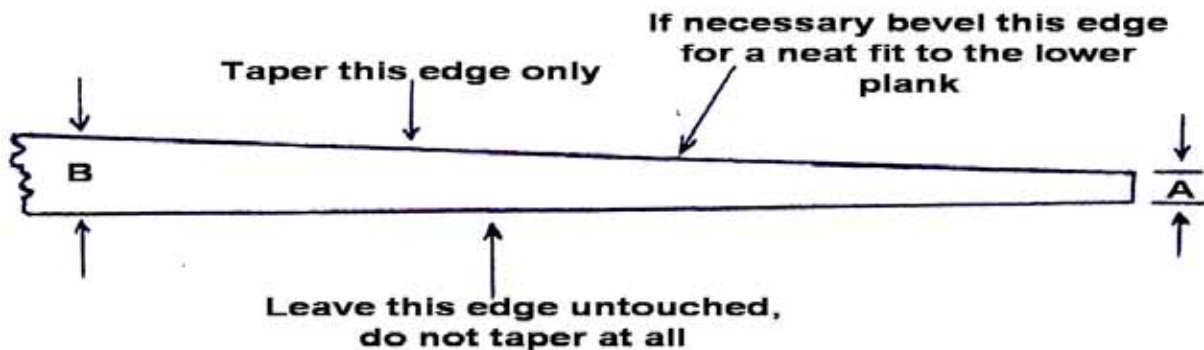

Figure 22

Note: In *figure 22* the hull is in the upright position. When tapering the hull planks taper the top edge of the plank only as indicated in *figure 22*.

Figure 23:

As with other rules tapering also has its rules governing what can and what shouldn't be done. Generally all tapering should be reasonably long to avoid sharp bumps and changes in direction. Any bumps which cause a plank to sit away from its neighbour will result in an unwanted gap between the two. The top diagram in *figure 22* shows the gap that can result where a taper is too short and does not give the upper planks lower edge a smooth surface to mate with. The lower diagram in *figure 22* shows correctly cut and mated planks.



Note: The next plank in this process will fit to the tapered edge. The next planks bottom edge is not to be tapered.

Figure 23

Figure 23A

As has been made mention several times before in this paper the garboard plank is the odd one out, where plank tapering is concerned the same applies. The garboard plank is the ONLY plank to be tapered on the upper edge when the model is in the upside down position as shown in *figure 23A*.

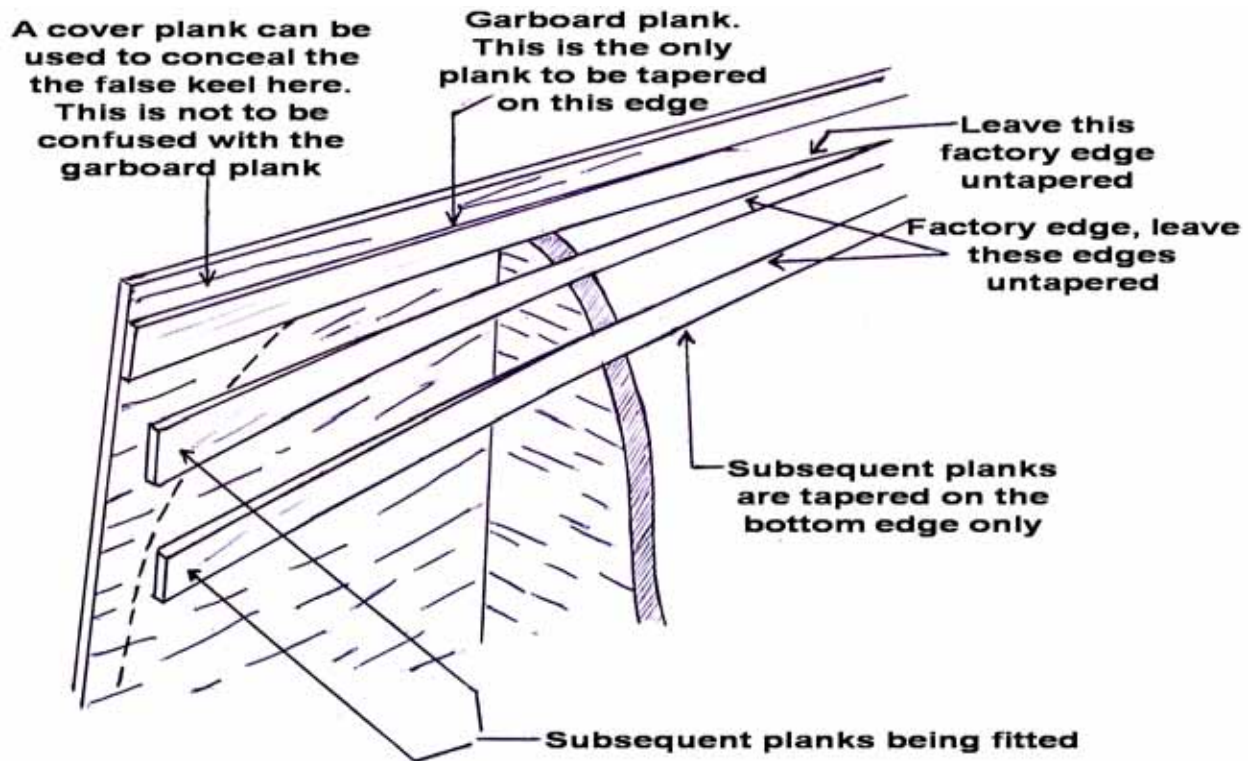
**Figure 23A****19. Beveling****Figure 24 & 24A:**

If you are intending to go with single layer planking then some beveling of the tapered edge of the plank will be needed. To gauge the amount of beveling required test fit the plank into position and take note of the location and amount needed to be bevelled. Sand as required to obtain an exact fit but remember final sanding and fairing of the hull will uncover any poor beveling resulting in a gap usually where you don't want it to be. If you are going use a second planking layer then beveling is not required as the second layer of planking will cover any gaps in the first. The second layer of planking is usually of thin veneer of 0.5mm so again beveling is not required in this instance.

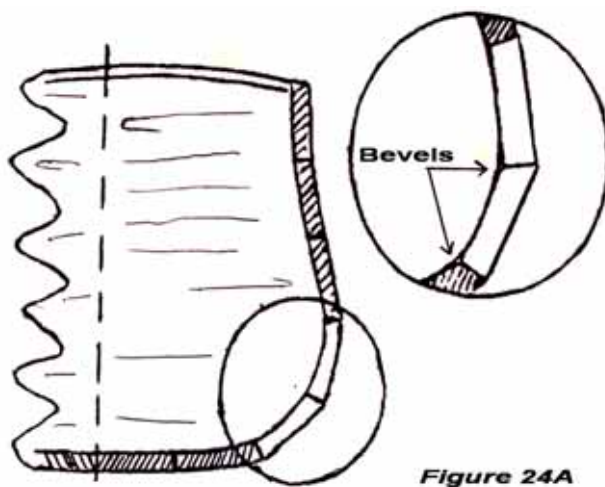
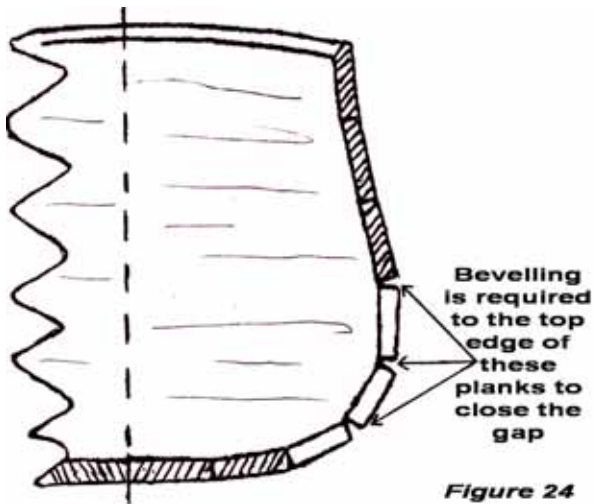

Note: Bevel the top edge of the plank only.

20. Fitting Gunport Frames Prior To Planking:

Figures 25 & 25A:

Again there are numerous ways to construct gunport framings. This is a just one method that I found worked extremely well for me. From the plans determine the location of the gunport openings on the various decks. Ensure that none foul the bulkheads or the rigging channels. If you already have glued and positioned the bulkheads, no matter as you can just add the gunport frames sections by section between the bulkheads. The overall end result will be the same. However my preference is the cut into the bulkheads prior to assembly and use full length runners or stringers as I can get a more flowing line for the ports. *Figure 25* shows what I mean by cutting into the bulkheads prior to assembly.

The depth of the framing is determined by the actual barrel length of the cannons being used. Don't forget to allow for the planking thickness along with the measurement. -A- is an example of the runner width to be used, don't forget to allow for a little protrusion of the cannon barrel beyond the ships side as if the cannon was run out ready to fire.

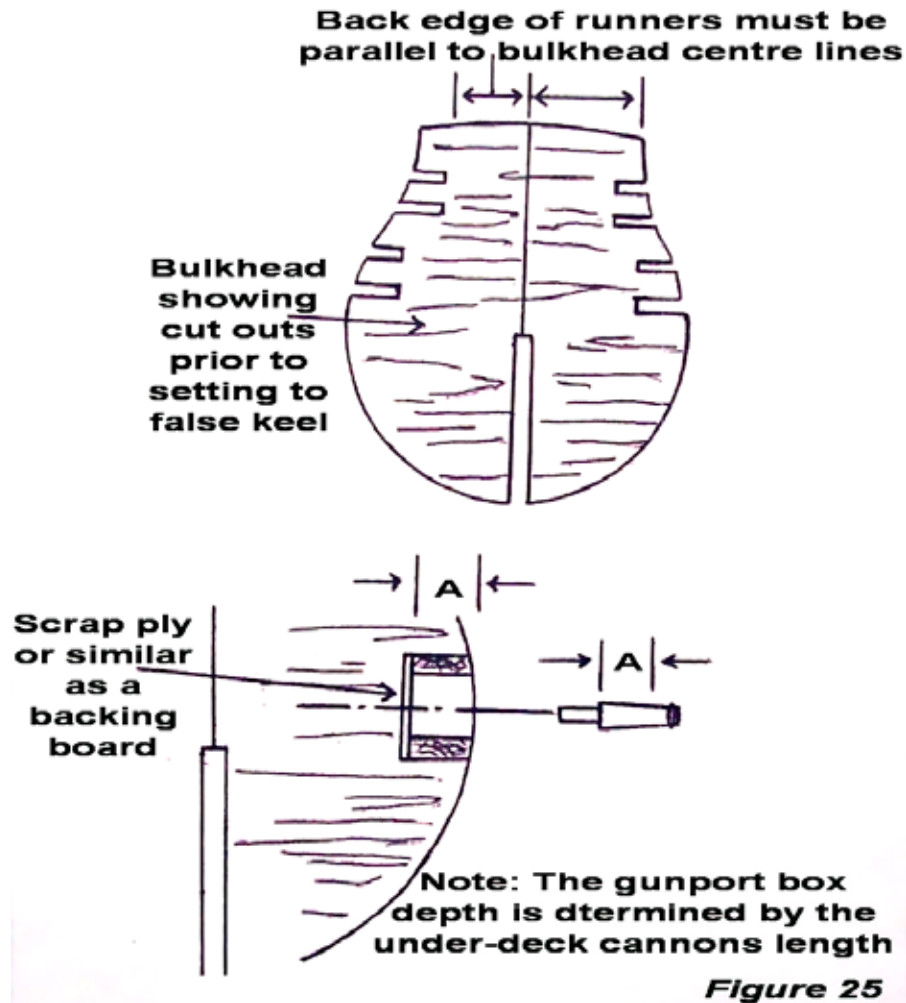

Material for the frames can be of any scrap timber available as they are not seen when the model is finished. The width of (A) top and bottom stringers may vary a little given the rounded shape of the hull, but always the inboard back edges of the runners must be vertical to each other (parallel to the bulkhead centre line). A piece of thin scrap ply is a good backboard for the framing to complete the box like construction. Don't forget to drill a hole in the back board dead centre as in *figure 25A*, to suit the lug on the inboard end of the cannon.

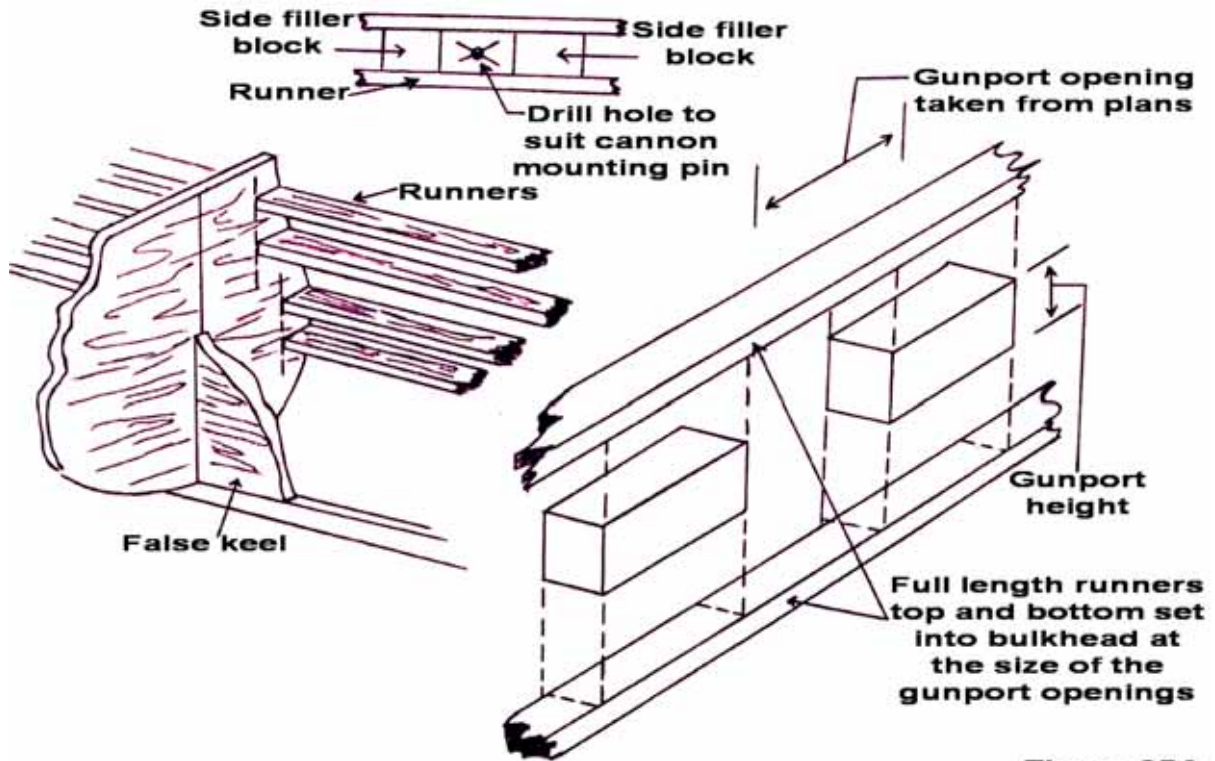

Figure 25A

Don't worry too much at this stage about the runners and side block framing not fitting exactly to the shape of the hull and bulkheads. This can be sanded down to the contour to the hull shape prior to planking. I find also it is a real advantage to paint the inside of the cannon port prior to planking. Matt black is my choice for this operation as it gives a sense of depth. Later the edges of the planking and the side blocks can be painted red it's your choice.

Note: Don't fit the cannons at this stage. These are fitted last of all as they tend to get in the way of everything and always get broken off.

21. Second Planking:

Figure 26:

If you decide to fit a second layer of planking, commence as you would with the first. If the first layer isn't looking as it should then you are going to have to use temporary battens and treat the whole operation as if it hasn't been done before. The garboard once again is the starting point.

Again this plank will be the odd one out and as such should be treated separately. However this time reduce the width a little so the joints between the next plank and this one don't sit on top of the first layer join. In other words stagger the joint. Eventually the joints will coincide with one another due to plank creep, this is unavoidable so don't worry about trying to correct it with a narrow or wider plank they will separate again as the planking progresses.

If you find the first layer of planking to be as you would wish but still want to go with the second its just a matter of following the first layer, again remembering to stagger the garboard plank as you start similar to the above paragraph. Work carefully plan well ahead and check frequently, after each plank is a good idea. Make sure the planks are flowing gracefully, don't bend a plank laterally, and don't glue it down until you are really sure the plank is lying correctly. I try to use carpenters glue for this operation as its slower setting and more forgiving. Use a little CA on the ends if you wish, both glues mix quite happily but remember CA works fast.

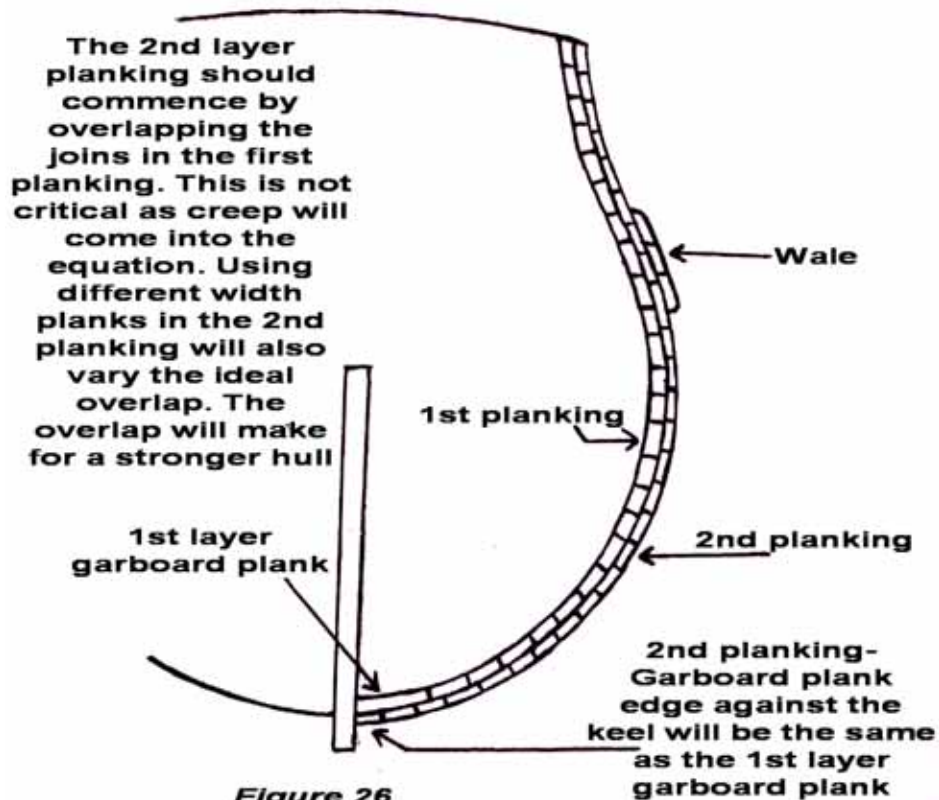

Avoid excess glue, if you do wind up with glue on the outer surfaces use a damp cloth to remove it while it's still wet as carpenters glue and CA will mar the surface and show through the varnish. CA of course can't be wiped off so use sparingly or wait till its well and truly dry and sand off the offending glue later.

Same planking rules apply to the second layer as to the first.

If you think you can work better with shorter lengths of planking do so if you wish, but be careful of bumps and variations in the width of some planks. Wood is not an exact material and some variations do occur. Scale the lengths of the planks to suit your model if you are going to use the short lengths. See *figure 20*; "Planking Rules", for scale plank lengths.

22. Spiling Operation:

Figure 27:

This would no doubt be one of the most interesting operations that can be performed in the planking operation. Spiling is used to obtain a correctly shaped odd plank where other than bending a plank laterally, the plank runs or curves away from the previous laid planks. A plank regardless of the hull shape should be allowed to lay in its natural position. Look at *figure 27* and imagine the paper card is a plank and it's not going to lay in the manner we want it to lay. That is a gap at the bow is evident between this plank and the previous one. Forcing it and bending it laterally is going to result in the clinker plank look. We don't want that as most hulls are carvel built, that is smooth with all planks butting edges against each other and not overlapped.

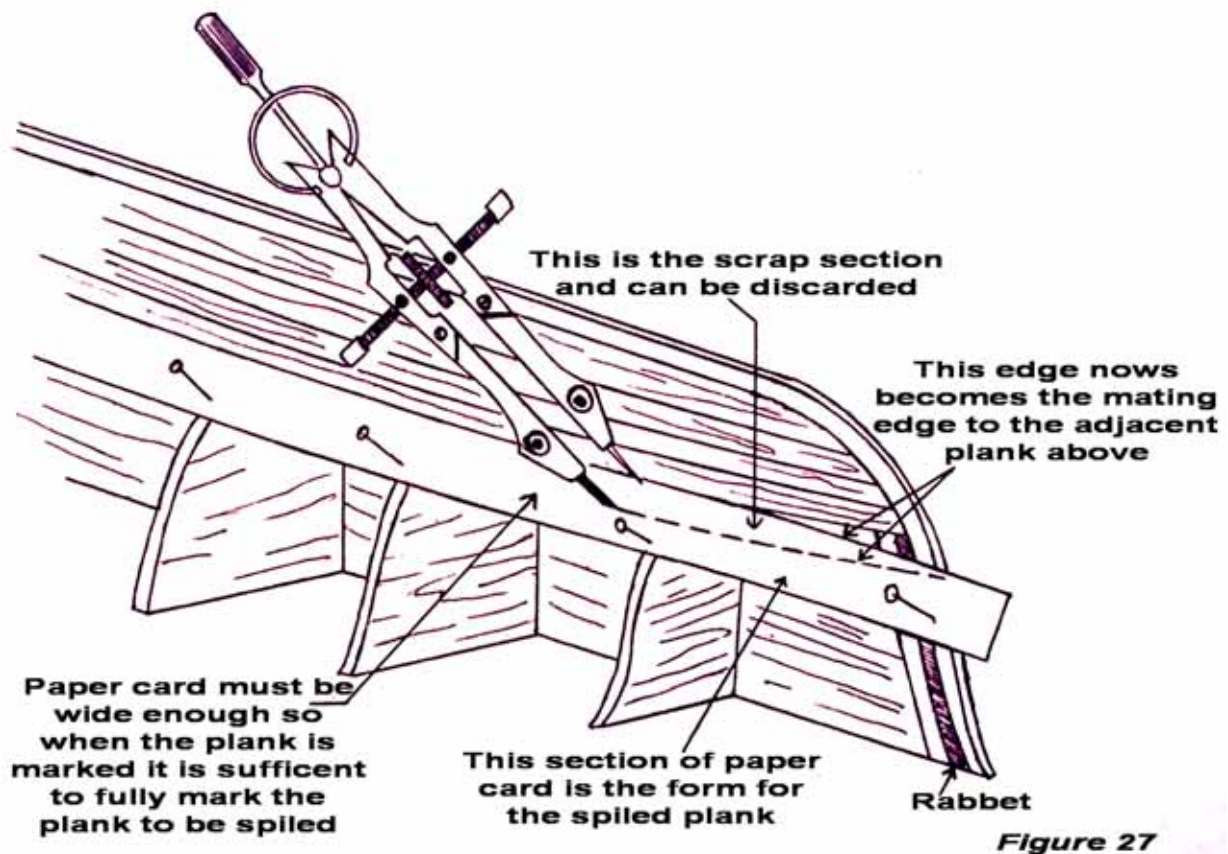

In the sketch the gap has to be overcome. By using a scrap of paper card, the cardboard back-cover of a writing pad is excellent for this operation. Cut a strip of card wide enough to allow suitable marking of the card to get the right shape of the spiled plank. More is better than too little in this case.

Figure 28, 29:

Temporarily pin the cardboard strip over the bulkheads with one edge securely fitted against the previous laid plank. Again do not force the card to fit the shape let it lay naturally as shown in *figure 27*.

Taking a compass with some means of locking the legs in position run the metal pointed leg against the lower edge of the previous laid plank as in the sketch. If you find the card sags just make a mark directly over the top of the bulkhead itself. This will form a series of dots or short marks that will be joined later to give the cutting line. Take the opportunity to mark the stem rabbet shape at this time to the card.

When this operation is complete remove the card from the hull and lay it over the piece of selected timber. Due to the shape of the spiled plank a wider plank than the normal planking timber is going to be required. This wider material of course needs to be the same thickness as the other planks being used. This rule applies to first as well as second layers of planking. Lay the card paper over the top of the wood, pin it into position to prevent it moving as you cut the shape. If you have used the dot method described above take a plastic ruler and possibly with a willing helper use the ruler on edge to join the dots using at least three dots at a time. Bending the ruler to suit this will form a graceful curve similar to the bending of a plank. Next mark the width of the plank using the spiled line as a guide. This plank should theoretically be the same width as the normal planks of the model. OK cut the outlined shape allowing a slight margin for sanding and snug fitting. You should wind up with something looking like the lower sketch in *figure 28*.

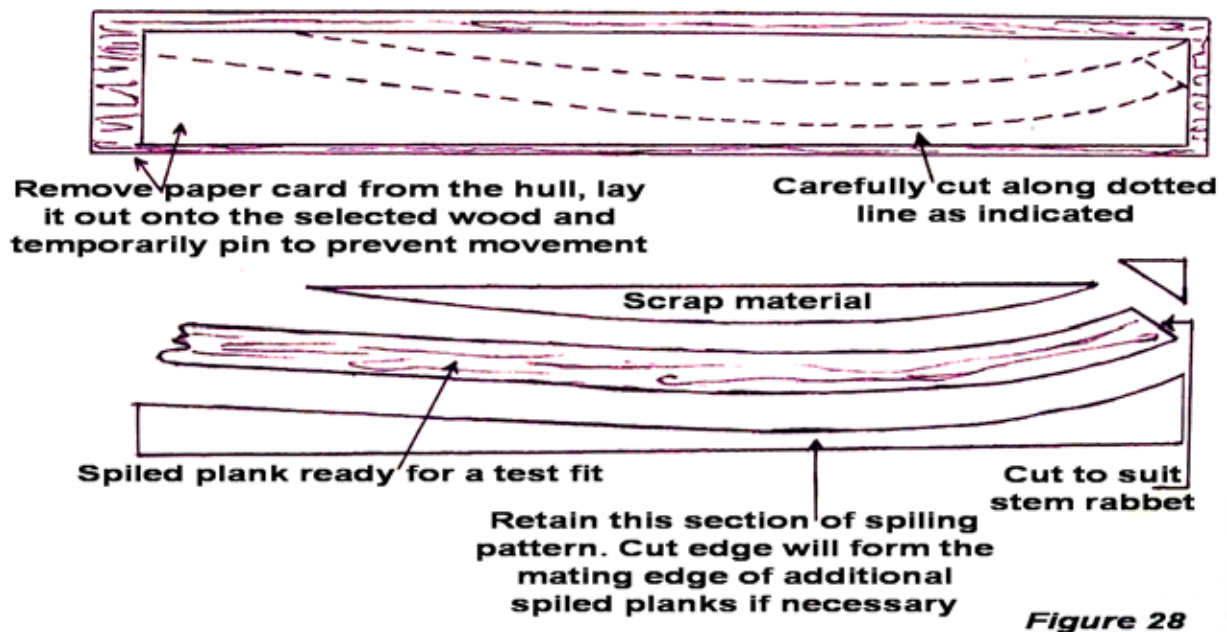
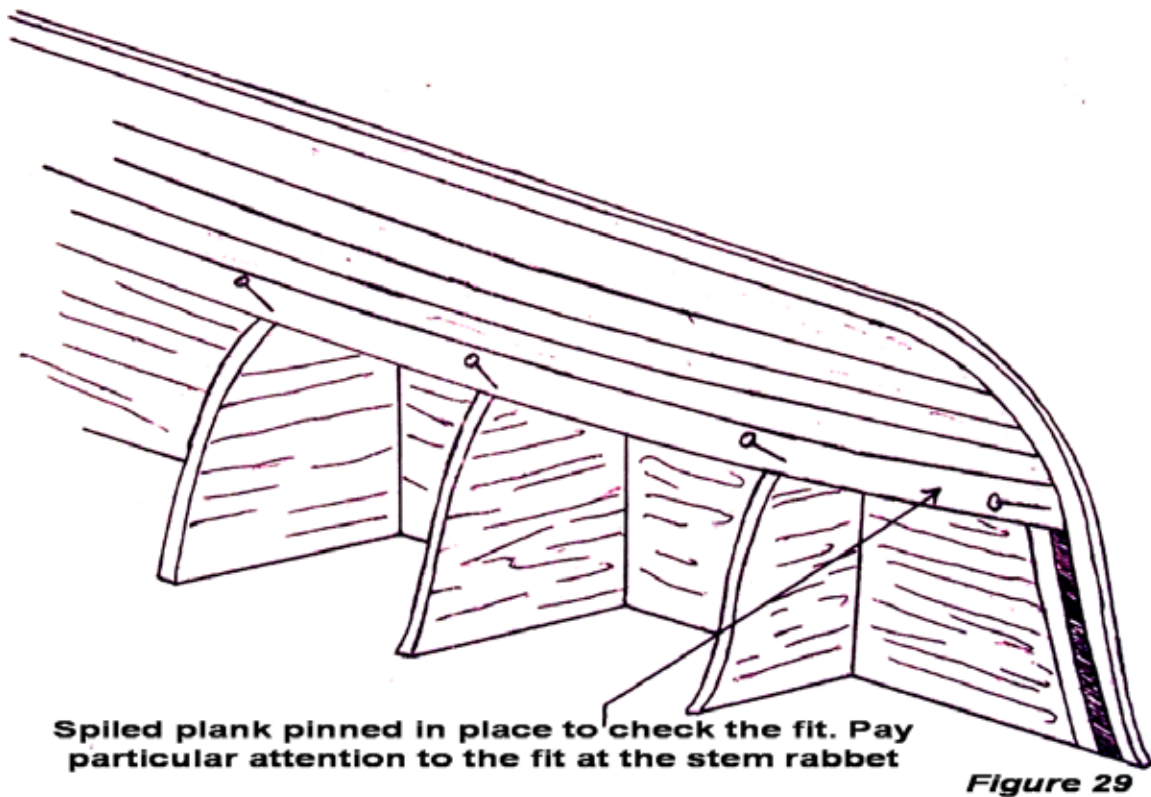

Figure 28

Discard the piece of card marked as scrap in the sketch. However retain the lower section as this shaped piece may be the next spiled plank required. A lot depends on the shape of the hull; it may be useful maybe not. Take you newly made plank and trail fit it to the hull, some sanding will probably be required to obtain a snug fit so take your time to get it right as you will be very aware of this plank as you made it. Pin to the hull look along its length if there are no gaps and all appears well glue it into position as in *figure 29*. Good job eh?



NOTE: If you are going with the single layer of planking some bevelling to the top edge may be needed. Again bevel only the one edge. See separate heading regarding bevelling procedure.

23. Sanding the Hull, 1st Layer:

Now that the planking operation is complete and you are happy with your work its time sand the hull smooth. I would recommend making up a sanding block using very coarse sand paper glued over the block. About 75mm by 30mm by 15mm is sufficient. This takes the edges from the planks quickly so take it easy and watch what you are doing. Of course use a finer grade if you are worried. Sand and feel with your fingers as you go bumps and lumps will need to be removed as these will certainly show up in the completed model. When you are truly satisfied with the result use finer grades until you get the desired surface finish you require. Remember sanding scratches will show if you don't finish with finer grade papers.

You will now need to protect the hull from mishaps and other ongoing work which may damage the hull so make up a temporary cradle to sit it in but place some protection between the hull and cradle, cloth material or blister/bubble wrap is good protection.

If you have any questions at all regarding this project don't hesitate to ask on the forum, there are numerous talented people in the group that are more than willing to offer advice and alternatives to the method described. You may well in fact find their methods and approach more suited to your style of building. Remember this method may not suit all hulls all the time so if in doubt ask. Good luck with the rest of your project and enjoy the experience.